

DELUXE STITCHER

C O M P A N Y I N C .

Machine Serial Number : _____

Head Serial Number : _____

Date Purchased : _____

Model M19 Stitchers

OPERATION AND MAINTENANCE MANUAL

M19-AST Stitcher....with 18D Head....115V and 60HZ

M19-BST Stitcher....with 18D Head....230V and 50HZ

M19G20-AST Stitcher..with G20 Head..115V and 60HZ

M19G20-BST Stitcher..with G20 Head..230V and 50HZ

Before using this Stitcher Head, all operators must study this manual and follow the safety warnings and instructions. Keep these instructions with the M19 Stitcher for future reference. If you have any questions, contact your local DeLuxe Stitcher Graphic Arts Representative or Distributor.

WARNING!

Model M19 Stitchers

Operators and others in the work area should always wear safety glasses to prevent serious eye injury from fasteners and flying debris when loading, operating, or unloading this machine.

Do not operate this stitcher without all guards in place. The stitcher will not operate without the front guard closed properly. Do not modify the guards in any way. Always disconnect the power supply before removing any guards for servicing.

Never operate the machine with wire feeding through the head unless there is stock above the clinchers, otherwise serious damage may result.

Always turn power off when making adjustments. Always disconnect the power supply before any disassembly work.

Table of Contents

Introduction	4
Assembly	7
Belt Guard Removal and Assembly	8
Cycling Machine Manually	9
Operating Adjustments	10
Adjusting the Machine for Thickness of Work	10
Recommended Wire Sizes	11
Adjustments and Settings.....	13
Adjusting the Clincher Points	13
Adjusting the Guides	15
Troubleshooting	16
Maintenance	17
Lubrication	17
Ordering and Replacing Spare Parts	18
Mounting & Removing Stitcher Heads	19
Clutch-Brake Maintenance	20
Assembly Drawings	27
Part Number / Description Cross-Reference	39
Registration Card	41
Warranty	43
Declaration of Conformity.....	44

Introduction

The DeLuxe Stitcher M19 Stitcher Machine is a single-head stitcher designed to accommodate both light and heavy-duty work, stitch both flat and saddle and is recognized for being the perfect stitcher for the smaller bindery due in part to its 3/4” (20mm) capacity and range of crown sizes.

The M19 accommodates both the Traditional Style 18D Head and the Side-Feed Style G20 Stitcher Head. Because either Head can be used the recommended wire sizes for the M19 are: 20 to 28 gauge round wire and 19x21-1/2, 20x24 and 21x25 flat wire. When ordering extra Heads, add the wire and crown size to the Head part number. For example: G20BHD20241/2.

18001BHDM19AST and M19BST
G20BHDM19G20AST and M19G20 BST

The M19 is easily adjusted from saddle work to flat work by tilting the 5-1/2” (14cm) x 26” (66cm) work table. An adjustable work guide and adjustable work stops are easily attached to the work table and provide for accurate registering of flat work for uniformly spacing the stitches. In addition a work table extension is provided to accommodate larger format work.

The M19 is foot-switch operated and belt driven by a 1/2 HP motor, making possible cycle speeds up to 200 stitches per minute. The motor is mounted on an adjustable bracket which can be raised or lowered to adjust driving belt tension. The driving mechanism is thoroughly shielded, preventing the possibility of personal injury.

The M19 has a 14” (36cm) throat depth for either flat or saddle stitching. The work table is approximately 35” (89cm) above the floor and there is approximately 1” (25mm) clearance between the top of the work to be stitched and the protective guarding around the stitcher head.

The M19 weighs 369 lbs. (168 kgs) net and the shipping weight is approximately 396 lbs. (180 kgs). With the table installed, the M19 requires about 33” (84cm) x 29” (74cm) of floor space.

Because of the length of the work table, the M19 must be secured to the floor to meet CE stability requirements. Sound level readings at the normal operator position are approximately 70 dB.

Specifications

Weight

Shipping Weight	396 lbs (180 kg)
18D Stitcher Head	17 lbs. (8 kgs)
G20 Stitcher Head	22 lbs. (10 kgs)
Wire Spool	5 lbs. (2.3 kgs) or 10lbs. (2.6 kgs) optional
Foot Switch	4.5 lbs. (2.0 kgs)
Table	10 lbs. (4.5 kgs)

Physical Dimensions

Height	65.0" (165.1 cm)
Width	
With Tables	33" (84 cm)
Without Tables	16" (50.8 cm)
Depth	29" (73.7 cm)

Stitching Capacity	Two Sheets to 3/4" (20 mm)
.	at 20# paper stock (75 grams/meter ²)

Wire Types	20-28 Round, 19x21-1/2,
.	20x 24, and 21x25 Flat

Throat Depth

Flat or Saddle.	14" (36 cm)
-------------------------	-------------

Side Stops	6-1/4 - 23-3/4" (15.9 cm-60.3 cm)
-----------------------------	-----------------------------------

Power Requirements

M19-AST or M19G20-AST	115VAC 60 Hz
M19-BST or M19G20-BST	230VAC 50 Hz

Minimum Recommended Circuit Capacity

M19-AST	8.1 A
M19-BST	5.8 A

Installation

Pre-Inspection

Carefully inspect the condition of the shipping container before unpacking your M19 Stitcher. If the container is broken, damaged or has been tipped over and there is evidence that the machine may be damaged, immediately notify the carrier who delivered the machine and the DeLuxe Stitcher Graphic Arts Representative from whom the M19 was purchased.

Inspection

As you carefully unpack the machine, check to make sure all components were delivered and are in good working order. Refer to **figure 1** in this manual for reference to the following pieces:

- M19 Manual
- Complete Table Assembly (K1033) with two Work Stops (7423), two Thumb Screws (425), a Work Guide (M7201B), two Binder Screws (63), two Washers (PW14) and a Work Table Extension (7056).
- Wire Spool (2024G5), Spool Stud (7693), Plastic Washer (M11009), Tension Spring (7690), Set Collar (7691) with Thumb Screw (P2731), 9/16 Washer (PG10271), Spool Washer (2245), 3/8 Washer (PW38), Hex Nut (HN3816). The Spool Bracket (G30144), along with two (2) 1/4" Screws (UA1420.1), Zinc Washers (PW14.2) and Lock Washers (LW14) secured to the Left Guard.
- Wire Guide Spring (15150A or G20286A).
- **18D Head accessories include:** Driver Release Pin (5160).
- **G20 Head accessories include:** the Complete Wire Guide Spring Plate Assembly (G20278AA), a set of 2.0, 2.5, 3.0 and 5 mm Hex Key Wrenches (G20361, G20360, G20362 and G20374) and an Open End Wrench (G20364).
- Stitch Samples

Pre-Installation

Please take a few moments to fill out the registration card located on page 41 prior to beginning installation.

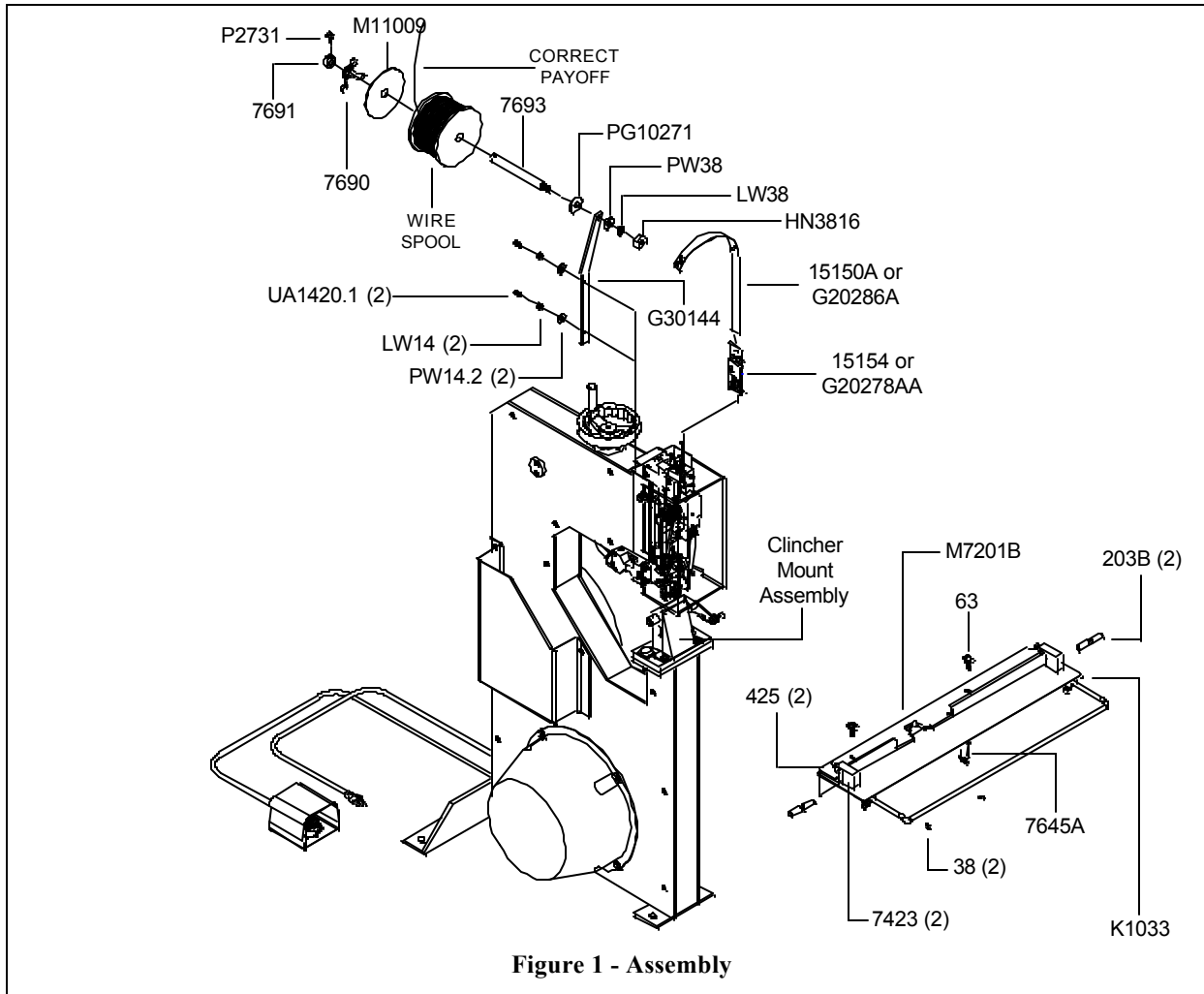

Always disconnect the power supply before making any adjustments or servicing the stitcher.



Assembly (Figure 1)

Some assembly is required upon delivery of the M19 Stitcher. You will need a flat screwdriver and a 9/16" open end wrench. Remove the packing materials from around the M19 and all contents from the shipping boxes. Mount the Spool Bracket (G30144) to the outside of the Left Guard (G30143) with two (2) Hex Head Cap Screws (UA1420.1), through two (2) Plain Washers (PW14.2) and two (2) Lock Washers (LW14). Locate the Spool Stud (7693) and remove the Hex Nut (HN3816), Washer (PW38) and Lock Washer (LW38) from the one end. Insert the threaded end of the Spool Stud into Spool Bar Bracket. Replace the Washers and Hex Nut. Loosen the Thumb Screw (P2731) in the Set Collar (7691) to remove it and the Tension Spring (7690) from the Spool Stud. Slide the Wire Spool over the Spool Stud, making

sure that the Flat Washer (PG10271) is between the Spool and the Wire Spool Bracket. **Also verify that the wire payoff is identical to the payoff in Figure 1; from left to right.** Improper wire payoff will result in poor stitching. Slip the Plastic Washer (M11009) over the Spool Stud and replace the Tension Spring and Set Collar. Apply slight pressure on the Set Collar, pre-loading the Tension Spring, then tighten the Thumb Screw in the Set Collar until secured. Mount the Wire Guide Spring (15150A or G20286A) in the Wire Guide Spring Bracket (15154 or G20278AA). A properly set Tension Spring will cause the Wire Guide Spring to flex but not actually hit the wire spool. The Tension Spring is designed to prevent the Wire Spool from over-running and tangling.

Loosen the two (2) Set Screws (38) in the bottom of the Complete Table Assembly (K1033) and pull the two (2) Pins (203B) in the Table out to each side. Center the Table Assembly over the Clincher Mount Assembly and make sure the Table Support (7648) is under the pin on the Table Support Bracket (7645A). Push the two (2) Pins from the Table into the Mount Assembly until they click. Tighten the two (2) Set Screws to further secure the Table to the M19. Make sure the Table converts from the flat to saddle position when the Table Support Bracket is activated.

The Work Guide (M7201B) can be attached to the Complete Table Assembly with two (2) Work Guide Screws (63). The two (2) Work Stops (7423) can be secured to the Work Guide by tightening the two (2) Thumb Screws (425).

Belt Guard Removal and Assembly (Figure 2)

The plastic Belt Guard (7676) must be removed before the M19 can be turned over manually. To remove the Belt Guard, remove the Retaining Screw (G30163) from the top of the Guard (on BST models only). Press on one side tab while prying out the locking face, at the top of the Guard. Next, pull down slightly on the top of the Guard to release the bottom tab. The Guard will now be free to lift off from around the Belt Guard (7675).

To reassemble, interlock the bottom tab and pull up slightly on the Guard to interlock the side tab, then squeeze the two halves of the Guard together to lock the remaining tab. Reassemble the retaining screw at the top of the Guard (on BST models only).

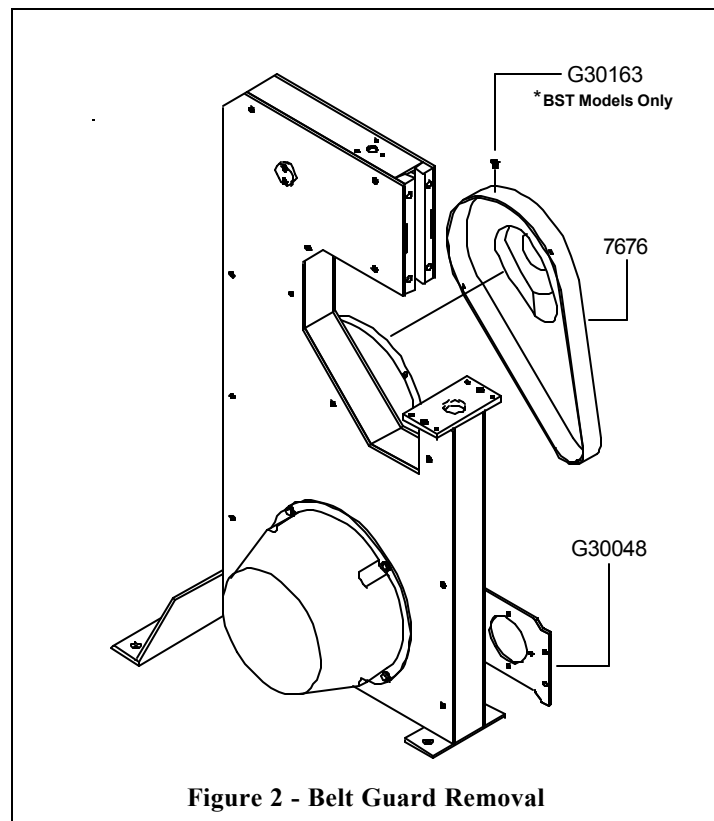

Always disconnect the power supply before making any adjustments or servicing the stitcher.



Cycling Machine Manually / Adjusting the V-Belt (Figure 3)

To turn the machine manually, it is first necessary to disconnect the power and remove the Belt Guard (7676), see the section “Belt Guard Removal” on page 8. Locate the Actuator Assembly (850992) on the Wrap Spring Clutch (850673 or 850674) and push the Actuator so that it pivots away from the Control Collar Cam (850888), releasing the Brake Hub (850892). The machine will rotate one revolution when the Drive Pulley (7678) is turned manually in the direction of the arrow on the pulley.

Note: If stalling or hesitation occurs during operation, the Belt may need to be tightened.

To tighten the V-Belt (850730C) first loosen, but do not remove, the four (4) Hex Nuts (HN3816) on the Motor Mounting Plate (G30048). Tighten the four (4) Hex Nuts again when the V-Belt is taut. If the Belt is not tight enough by force of gravity, wiggle both the Motor Plate and Motor (on the other side of the Stitcher) slightly until it is. Do not press on the Motor arm to make this adjustment as pressing on the Pulley may knock it out of position. The V-Belt should first be tightened after two to three weeks of use and then periodically after that. Moisture, change in temperature as well as wear can affect the tightness of the Belt. Loose Belts can cause the Stitcher to stall and may damage the Belt permanently.

Note: Over tightening the Belt can damage the main bearing on the motor.

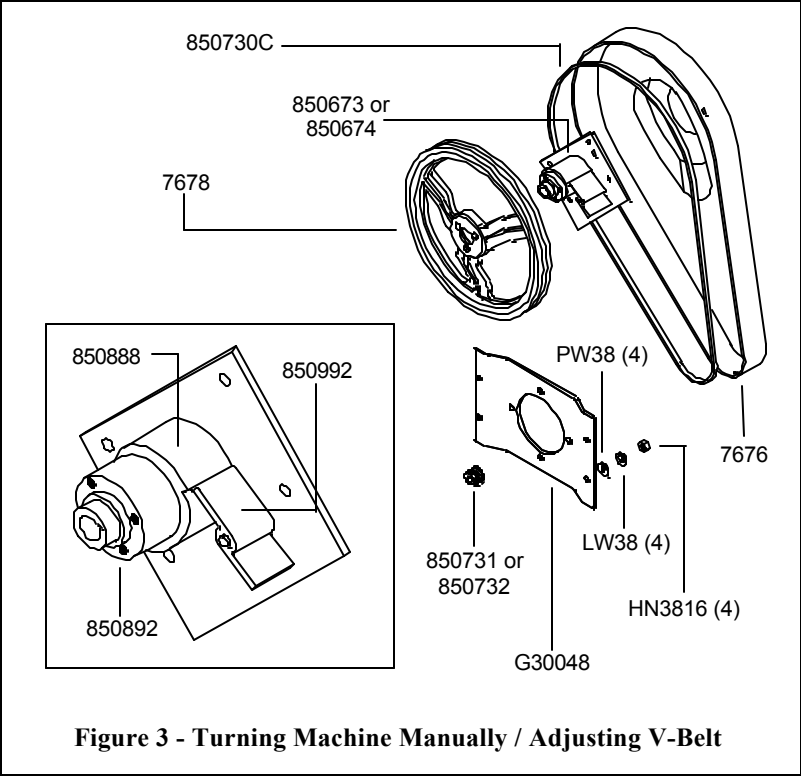

Operating Adjustments

The quality and quantity of work that can be stitched on the M19 is dependent upon the operator making the necessary operating adjustments as accurately as possible. The following information and instructions are provided so that the operator will clearly understand how to make the required operating adjustments.

Additional Operator's Manuals for the stitcher heads supported by the M19 Stitcher are included with the Stitcher itself. Please refer to these manuals for specific instruction and operating adjustments for the individual stitcher heads.

Failure to properly adjust for the compression will severely damage the stitcher.

WARNING

Adjusting for Thickness of Work (Figure 4)

Unlock the Hand Wheel (G30128) by turning the Adjuster Crank (G30175) on the Adjuster Crank Housing (G30099B) counter-clockwise. Turn the Hand Wheel clockwise until the Adjuster Spool (G30119) is raised sufficiently to allow a sample of work to be inserted between it and the lower Adjuster Stop (G30103).

Note: A sticker located near the Hand Wheel indicates the direction of operation.

The thickness gauge is located on the right-hand side of the machine if you are looking from the front of the stitcher. With the work held flat in a horizontal position, turn the Hand Wheel counter-clockwise until the work is firmly clamped between the Adjuster Spool and the lower Adjuster Stop. Turn the Hand Wheel back clockwise just enough to

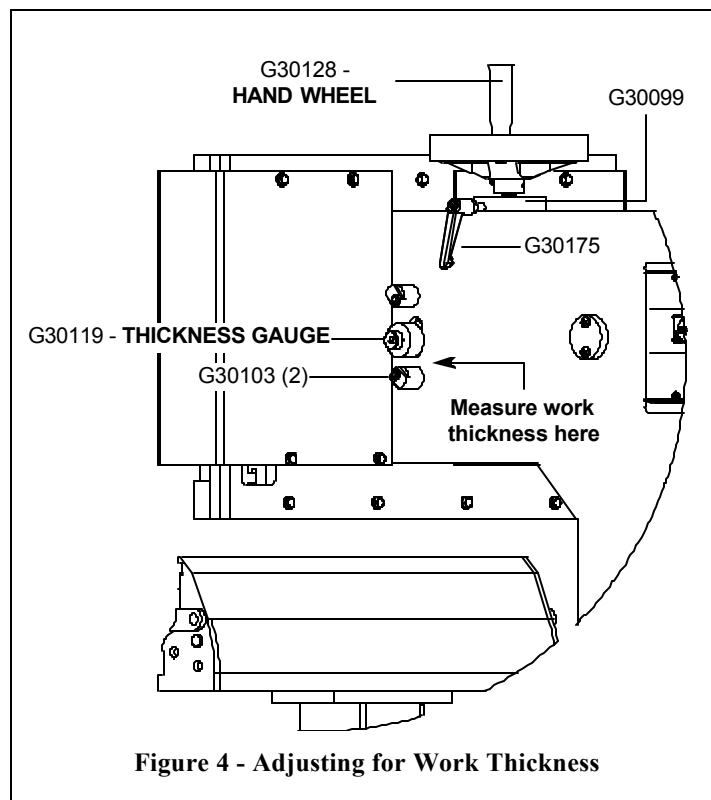

Figure 4 - Adjusting for Work Thickness

allow the work to be withdrawn from the Adjuster Spool, then return the Hand Wheel to the setting at which the work was clamped.

Anytime the thickness of work changes, a sample should be tested in the M19 so no serious damage is caused to the machine. If the machine is operated on work thicker than it is set to handle, damage will result and the stitcher machine will not operate properly.

If the machine is operated on work thicker than it is set to handle, damage will result.

⚠ WARNING

Recommended Wire Sizes (Figures 5 and 6)

The wire sizes that can be used on the M19 as well as recommended uses are listed below. Refer to the Operator's Manual for the Stitcher Head on your M19 when changing the existing wire size. The Stitcher Heads are designed to accommodate a specific wire size. Wire gauges smaller than the specific size for the stitcher head can still be used, but the maximum capacity for that head will not be reached. For example, a 19x21-1/2 gauge wire head will function properly with 20x24 gauge wire but the stitching capacity for the Head will drop from 3/4" to approximately 1/2". Refer to **Figure 5**.

Two types of Clincher Points are provided with the head on the M19. When running round wire, use the Clincher Points with part number **7257B**. When running flat wire, use the Clincher Points with part number **7024B**.

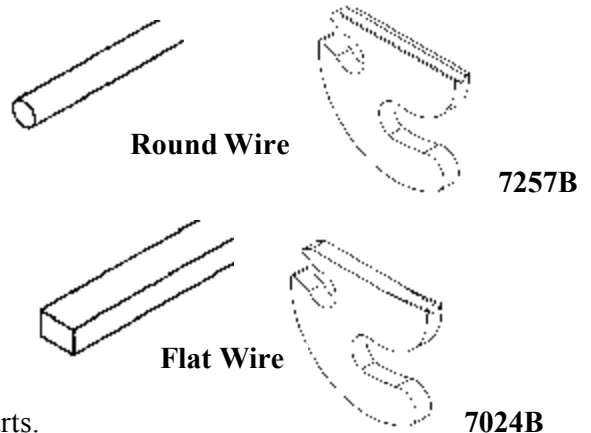

When stitching stock over 20# it is recommended that a high tensile wire be used, which is available in 21x25, 20x24 and 19x21-1/2 flat wire sizes. The high tensile wire may cause increased wear on certain parts. For any stock over 33# or coated stock it is recommended that 19x21-1/2 flat wire be used. Refer to **Figure 6** for a general overview of suggested wire sizes to use for specific stitch capacities.

Stitcher Head Parts *	Wire Gauge Used	Max Capacity
20 Gauge	23 Round	2 Sheets to 1/8"
	22 Round	2 Sheets to 3/16"
	21 Round	2 Sheets to 1/4"
	20 Round	2 Sheets to 3/8"
	21x25 Flat	2 Sheets to 3/8"
	20x24 Flat	2 Sheets to 1/2"
24 Gauge	27 Round	2 Sheets to 1/32"
	26 Round	2 Sheets to 1/16"
	25 Round	2 Sheets to 1/8"
	24 Round	2 Sheets to 1/4"
20x24 Gauge (standard)	25 Round	2 Sheets to 1/8"
	24 Round	2 Sheets to 3/16"
	21x25 Flat	2 Sheets to 3/8"
	20x25 Flat	2 Sheets to 1/2"
	20x24 Flat	2 Sheets to 3/4"
19x21-1/2 Gauge	25 Round	2 Sheets to 1/8"
	24 Round	2 Sheets to 3/16"
	23 Round	2 Sheets to 1/4"
	22 Round	2 Sheets to 5/16"
	21x25 Flat	2 Sheets to 3/8"
	20x25 Flat	2 Sheets to 3/8"
	20x24 Flat	2 Sheets to 1/2"
	19x21-1/2 Flat	3/8" to 3/4"

Figure 5 - Limited Stitching Capacities

* Both the 18D and G20 Heads can be equipped with these specific wire gauge parts.

Wire Gauge	Type of Work	20# Stock
28 Round	Light Flat or Saddle	2-5 Sheets
27 Round	Light Flat or Saddle	2-5 Sheets
26 Round	Light Flat or Saddle	2-10 Sheets
25 Round	Medium Flat or Saddle	2-40 Sheets
24 Round	Medium Flat or Saddle	2-60 Sheets
21 x 25 Flat	Heavy Flat Only	Over 50 Sheets 1/4" - 3/8"
20 x 25 Flat	Heavy Flat Only	Over 50 Sheets 1/4" - 1/2"
20 x 24 Flat	Heavy Flat Only	Over 50 Sheets 1/4" - 1/2"
19 x 21 1/2 Flat	Heavy Flat Only	1/2" - 3/4" and Heavy Paper

Figure 6 - Recommended Wire Sizes

Disclaimer: Maximum stitching capacity specifications depends on wire and material type used.

Adjustments and Settings

Adjusting the Clinchers (Figures 7 and 8)

If the staples are not clinching properly the Clincher Points (7024B or 7257B) will need to be adjusted within the Clincher Plate (7253A). Make sure the Table Assembly (K1033) is in a flat work position. If it is not, tilt it back until the Table Support Bracket locks the Table into place. Loosen and remove the two (2) 1/4-20x5/8 Screws (UA4810.5) securing the Clincher Guard (G30113) to the Clincher Mounting Assembly (G30044A). Be careful to also remove the two (2) Lock Washers (LW14) and Plain Washers (PW10). Check the Clincher Point height by cycling the machine manually and stopping it at the top or highest point of Clincher activation. Loosen the Set Screw (UA1428.1) in the Adjustment Block and rotate the Clincher Slide Adjustment Screw (18186), which raises or lowers the Clincher Slide (18182), to adjust the Clincher Points as needed. Rotating the Screw clockwise lowers the Points, while rotating the Screw counter-clockwise raises the Points.

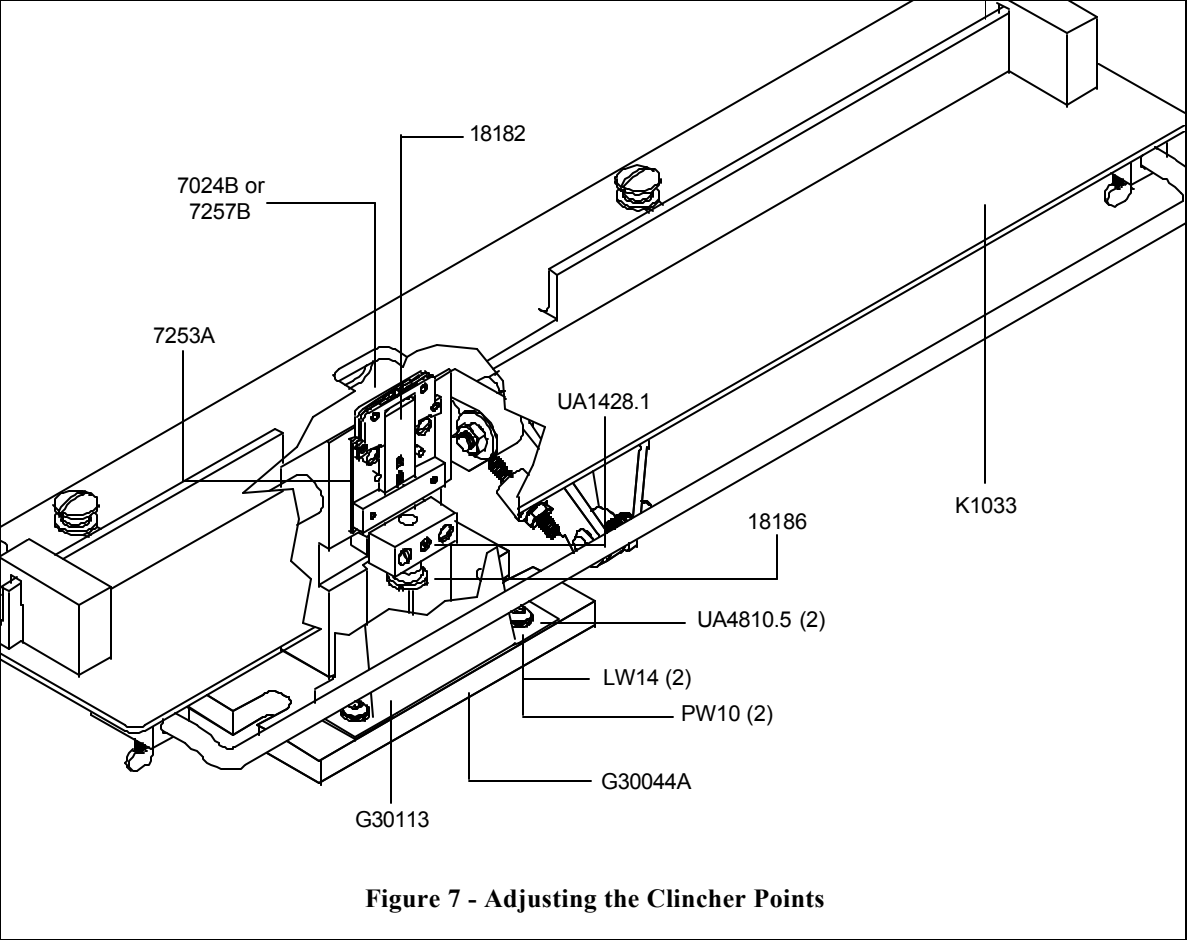

Tighten the Set Screw and replace the Clincher Guard with the Screws and Washers. Complete the cycle of the machine and test a few stitches. Repeat the previous steps if necessary.

If the stitch clinches properly but the legs are angled away from its crown, the Clincher Plate may not be aligned with the Stitcher Head's Driver. Refer to both **Figure 7** and **Figure 8** and the following instructions for directions on centering the Clincher Points.

Coarse Adjustment

Although the Clincher Plate alignment is set at the factory, it can be adjusted. With wire threaded through the machine and the compression set to 1/8" turn the machine over manually, but stop as the staple begins to exit the Bender Bar. Loosen the two (2) 1/2-20x1-1/4 Screws (G30159) securing the Clincher Mount Assembly (G30044A) to the M19 Frame. Using this half-formed staple, line up the legs of the staple with the Clincher Points from back to front as well as from side to side.

Once the legs of the staple are aligned, the Driver will be centered above the Clincher Points and the quality of the stitch will be greatly improved. Tighten the Screws to secure the Clincher Mount Assembly in this position. Complete the machine's cycle and remove the formed staple so as to not jam the Clincher Points.

Fine Adjustment

For fine adjustments, refer to the Stitcher Head's Operation Manual. Specifically, refer to the section of the manual which highlights making adjustments to the Leveling Screws on the back of the Stitcher Head.

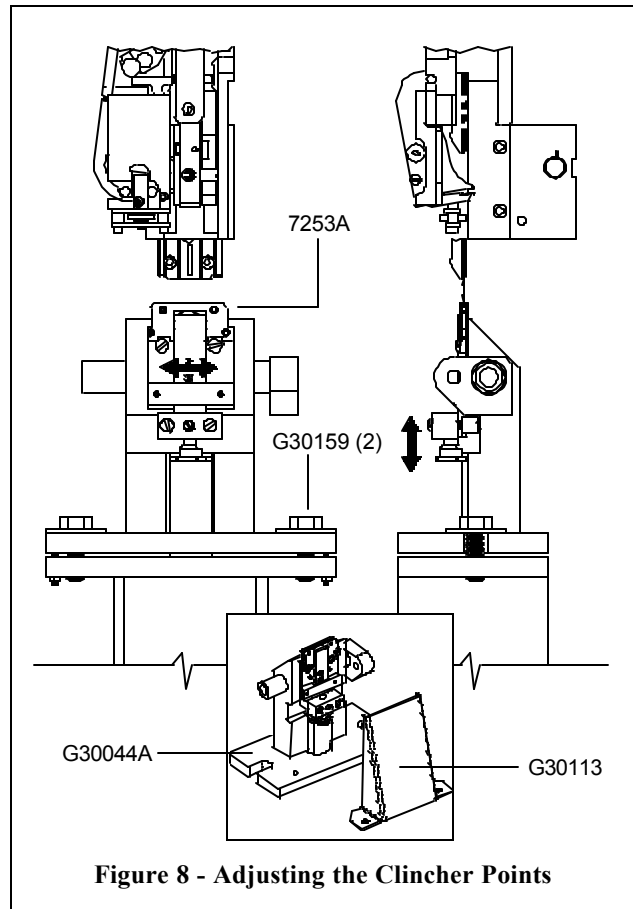

Figure 8 - Adjusting the Clincher Points

Adjusting the Work Stops (Figure 9)

The Work Stops, which are included with all M19 Stitchers, ensure consistent placement of stitches time after time. Both types of Stops available perform a different and specific function. Use the Work Guide, set of Work Stops, or both depending on the application at hand.

Work Guide

The Work Guide (M7201B), sometimes referred to as the Back Guide, is controlled by two (2) Work Guide Screws (63). The slots in the rear of the Guide allows free placement of the Stop. Slide the Work Guide back and forth until the the location on the stock being stitched is under the Driver. Once the ideal location is determined, the two (2) Work Guide Screws are tightened and the Guide is locked into place. Two (2) Table Extender Brackets (7659) are attached to the Work Table Assembly (7656A) for additional Work Guide placement. To use these extensions, loosen and remove the two (2) Work Guide Screws and insert them in the Extender Brackets. Slide the Work Guide back and forth until the proper stop location is found and tighten the Screws as before.

Work Stops

The two (2) Work Stops (7423), sometimes referred to as the Side Guides, are controlled by two (2) Thumb Screws (425). Slide each of the two (2) Work Stops along the Work Guide until the desired location on the stock being stitched is under the Driver. Once the perfect position is found, tighten each of the two (2) Thumb Screws.

Troubleshooting

The following is a brief list of problems and solutions which should cover the majority of situations encountered when stitching with the M19. The quality and quantity of work that can be produced with the M19 Stitcher is dependent upon the operator making all adjustments as accurately as possible and carefully maintaining the machine. The cause of staple imperfections usually can be traced to inaccurate settings or normal wear of moving parts. In these events, the operator can quickly locate the solutions, by referring to the following troubleshooting chart.

Note: Most stitch quality issues are addressed in the Stitcher Head manual.

PROBLEM: The machine will not complete a cycle, under power or manually.

SOLUTION:

1. Make sure the compression setting is correct. If not turn the Hand Wheel (G30128) clockwise to raise the stitcher head.
2. If the V-Belt is too loose it must be tightened.
3. Make sure none of the Clutch Springs are broken and that the Clutch has not failed. If either are the case, replace the component or the entire assembly.

PROBLEM: The machine will not begin a cycle at all.

SOLUTION:

1. Make sure the Interlock Switch Key (850343) on the plastic Head Guard (G30145) is in complete contact with the Safety Interlock Switch (850308) on the Left Guard (G30143).

PROBLEM: Stitch quality is poor.

SOLUTION:

1. Refer to the Stitcher Head Operator's Manuals for more information.
2. Make sure that the wire is feeding straight from the Wire Spool and through the Stitcher Head.
3. Make sure the compression setting is correct.
4. Make sure the Clincher Plates are lined up with the Stitcher Head's Drivers, both side to side and front to back.
5. Make sure the Clincher Points are not set too high or too low.
6. Make sure the left leg of the stitch is same length as the right leg.

PROBLEM: Wire is dropped before it can be formed, drawn in inconsistent lengths or is jamming.

SOLUTION:

1. Refer to the Stitcher Head Operator's Manuals for more information.
2. Make sure that the wire is feeding straight from the Wire Spool and through the Stitcher Head.
3. Check for worn parts on both the Stitcher Head and on the M19 itself.
4. Make sure the Clincher Points are clear of debris and paper build-up.
5. Make sure the Clutch is set to stop 1/8" prior to top dead center at the end of a cycle.

Maintenance

Lubrication (Figure 10)

Your M19 Machine has been fully lubricated at the factory, but regular preventative maintenance will result in superior performance and a longer life of the machine. Machines that are in constant use should be lubricated weekly where as machines that are only operated periodically should be lubricated just prior to use. Usually only a drop of oil is required at each lubrication point. Care must be taken that those parts of the machine that contact work remain free from oil. Refer to the Stitcher Head Operator's Manuals for more information on the lubrication needs for the individual Stitcher Head on the M19 Stitcher.

Lubricate regularly instead of excessively.

Excessive oiling will result in work becoming oil-spotted. After lubricating the machine, wipe off any excess oil. Use one drop of any standard S.A.E #10 oil in the following lubrication points:

- the lubrication points for the individual Stitcher Heads. (see specific Stitcher Head Manual)

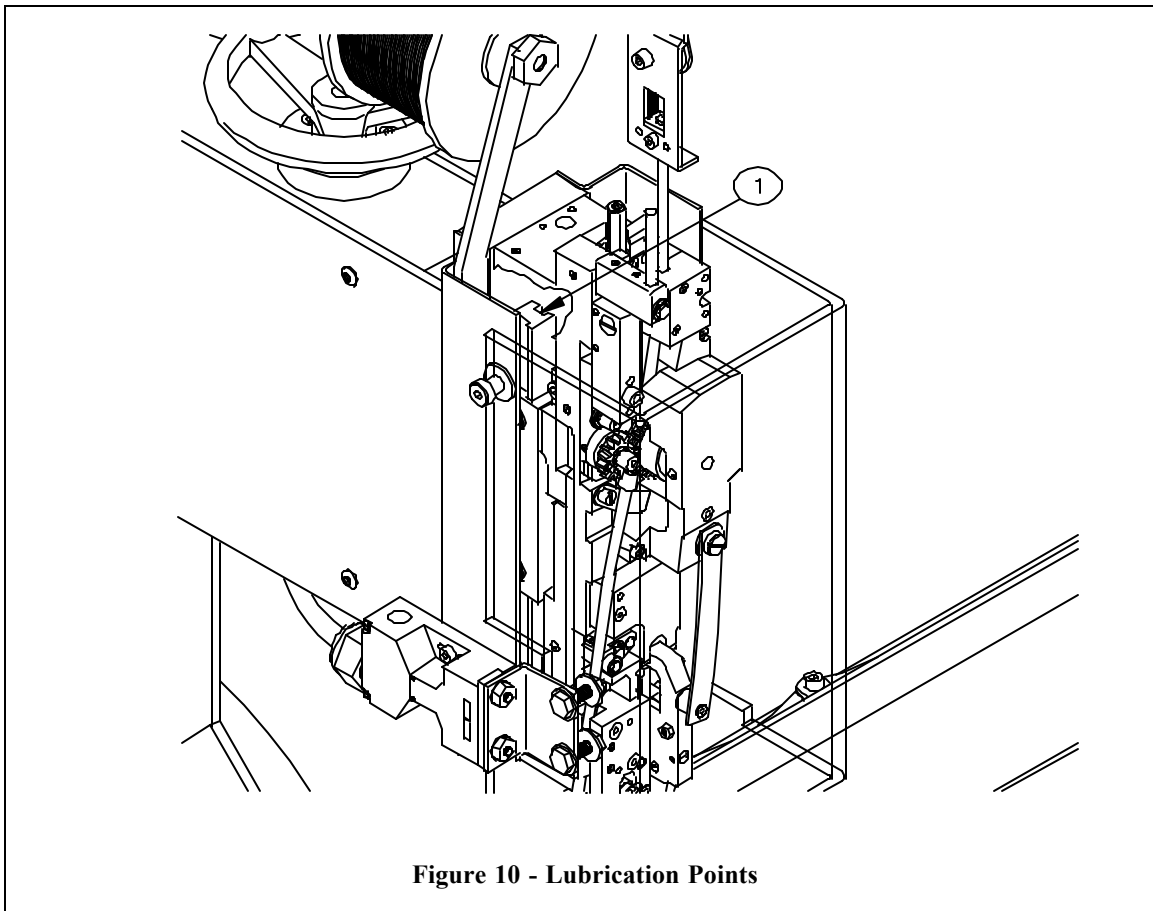

Figure 10 - Lubrication Points

High friction areas, on the machine interior, should be lubricated with Red E-Lube Grease or any other Lithium-based grease once a year to prevent the areas from drying out. Remove the Screws (UA4810.5), securing the Left Side Cover Plate (G30002) to expose the internal assemblies. Apply Grease in the following areas:

- the Bender Cam Assembly (G30066A)
- the Crank Shaft Assembly (G30007A)
- the Cam Guide (G30025)

Ordering Spare Parts

In time, you may need to replace some parts of the M19 Stitcher Machine. To do this locate the DeLuxe/Bostitch part number in one of the following diagrams and contact your Graphic Arts Representative to order the replacement by part number, description and quantity.

Always disconnect the power supply before making any adjustments or servicing the stitcher.

⚠ WARNING

Replacing Spare Parts

The operator should periodically inspect all moving parts for signs of wear and when required, replace those worn parts. For a complete list of common stitcher head wear parts, refer to the Operator's Manual of the specific head.

Mounting & Removing Heads

The M19 Stitcher Machine is a single-head Stitcher Machine. But the time may come when a replacement Head may have to be added or removed from the stitcher. The following are guidelines for mounting and removing both an 18D and a G20 Stitcher Head to or from the M19.

To mount an 18D Stitcher Head on the M19: Slip two (2) Bonnet Binder Stud Pins (G30148), through two (2) Bonnet Binder Studs (2609) at both the top and bottom of the 18D Head. Position the Bender and Driving Slides of the 18D approximately where they will align with the Bender Plate and Driver Plate Adapters on the M19. Insert the Binder Stud, in the bottom of the 18D Head, into the lower hole of the Face Plate Adapter (G30026) on the M19 Stitcher. Start one (1) Bonnet Stud Nut (HN1213) on the Binder Stud to steady the bottom of the Head; just tight enough so the Bender Slide does not slip off the Bender Plate Adapter. The Bender and Driving Slides may have to be adjusted manually to match up with the Adapters on the M19. Insert the Binder Stud, in the top of the 18D Head, into the upper hole of the Face Plate Adapter. Before starting the second Bonnet Stud Nut, make sure the Head's Face Plate Adjusting Slide aligns with the Driver Plate Adapter on the M19. A screwdriver used as a lever between the Driving and Adjusting Slides will facilitate the action. Completely tighten both the Bonnet Stud Nuts with a 3/4" Wrench.

To mount a G20 Stitcher Head on the M19: Slip two (2) Rear Clamp Pins (G20376) through two (2) Rear Mounting Bolts (G20341) at both the top and bottom of the G20 Head. Position the Bender Slide and Feed Slide Block of the G20 approximately where they will align with the Bender Plate and Driver Plate Adapters on the M19. Insert the Binder Stud in the bottom of the G20 Head into the lower hole of the Face Plate Adapter (G30026) on the M19 Stitcher. Start one (1) Bonnet Stud Nut (HN1213) on the Rear Mounting Bolt to steady the bottom of the Head; just tight enough so the Bender Slide does not slip off Bender Plate Adapter. The Bender Slide and Adjustment Block may have to be adjusted manually to match up with the M19. Insert the Binder Stud, in the top of the G20 Head, into the upper hole of the Face Plate Adapter. Before starting the second Bonnet Stud Nut, make sure the Head's Face Plate Adjustment Block aligns with the Driver Plate Adapter on the M19. A screwdriver used as a lever between the Driving Slide and Feed Slide Block will facilitate the action. Completely tighten both the Bonnet Stud Nuts with a 3/4" Wrench. The Clincher Plate Assemblies can now be aligned with the Stitcher Head, see pages 13-14 for more details.

To remove a Stitcher Head from the M19: While completely supporting the Stitcher Head, loosen and remove the two (2) Bonnet Stud Nuts until the Stitcher Head is released from the M19. Lift the Head off the M19 and set aside.

Clutch-Brake Maintenance

Always disconnect the power supply before making any adjustments or servicing the stitcher



This stitcher is equipped with a solenoid actuated, continuous trip, wrap spring clutch-brake unit. It is a dependable device and seldom needs service. But should a malfunction occur, the following information is a service and troubleshooting guide for the maintenance of this unit.

Actuator

The actuator is a simple, straight-forward mechanical linkage. When the actuator does not trip, the following checks should be made. Refer to **Figure 11** for more details.

Problem	Cause and Remedy
No power to the Coil	Check all wiring and switching in the Clutch actuating system.
Lack of continuity in the Coil Windings	Replace the Coil (850998 - 230 VAC or 850999 - 115 VAC)
Mechanical binding of the Plunger	The Coil may have shifted or the Plunger end may have mushroomed due to striking the Backstop. In the latter the Plunger may be filed to its true diameter.
Insufficient clearance for the Actuator over the Stop Collar	Adjust the Linkage as needed
Actuator loaded by the Stop Collar so hard that the Actuator cannot be pulled by the Coil.	Braking force is exceeding the limits of the Brake or the Differential setting of the unit is too close (see Figure 12 for instructions)

Figure 11 - Actuator Checklist

Clutch and Brake Springs

With the brake engaged (full limit of output), the input hub should be free to rotate by hand. With the clutch engaged, the input and output hubs should rotate together. If the unit does not rotate in either of these modes, the clearance between the hubs of the unit on the shaft may have been disturbed or damaged. See Assembly/Disassembly instructions for re-adjusting.

Listed below are additional checks to be made if the clutch does not function correctly. Refer to **Figure 12** for details.

Problem	Cause and Remedy
Clutch Brake does not drive but Input Motor turns	<ol style="list-style-type: none"> 1. Drive Spring (850889) may be broken at the crossover point from an overload caused by a jam. Replace the Spring and check the Hubs (851321 or 850892) for damage. 2. The Control Collar (850888) may not snap forward because of foreign matter restricting movement. Clean unit. 3. Actuator Assembly does not pull in. (Figure 28)
Clutch Brake jams and stalls Input Motor	<ol style="list-style-type: none"> 1. Spring tang broken off Drive Spring not allowing the Clutch to disengage while the Brake is engaged. Replace the Drive Spring. 2. Clutch output is bound up. Check the clearance between the Output Hub and the Brake Hub. 3. Completely out of adjustment caused by losing an internal Spring tang. Replace Spring.
Output does not repeat stopping point	<ol style="list-style-type: none"> 1. Not enough inertia to actuate Brake. 2. Tang broken off the Brake Spring. Replace the Spring. 3. Adjustable Collar Locking Screw may be loose allowing Adjusting Screw to rotate.

Figure 12 - Clutch and Brake Spring Checklist

Disassembly (Figure 13)

To disassembly the Clutch-Brake unit (850673 or 850674) it will be necessary to remove the Drive Pulley (7678B) from the stitcher by removing the V-Belt (850730C), Retaining Ring (P7863), and Clutch Anchor Screw (7681). Disconnect the Ground and Solenoid wires, and swing the Clutch Anchor (FC9656A) clear of the Drive Pulley Assembly and slide it off of the Drive Shaft. Remove the three (3) Screws (UA4812.7) connecting the Drive Pulley to the Clutch-Brake unit.

When disassembling the Clutch-Brake unit, always mark the Spring Tang locations with reference to which slots they go in if the same Springs are to be used for reassembly. To disassemble the Clutch-Brake unit, proceed as follows:

Release the Actuator Lever so that the Clutch is engaged and the Brake is released. Remove the Retaining Ring and the Shim Washer, if any, from the Input Hub (851321) end. Remove the Input Hub by rotating opposite to the drive direction. Remove the Retaining Ring and the Shim Washer, if any, from the Mounting Plate end.

Remove the Output Shaft Springs and the Control Collar (850888) Assembly by rotating the Output Shaft (850891) in the drive direction. **(Do not disassemble the Brake Hub (850892) from the Mounting Plate (850890).** Remove the Control Collar from the Output Shaft and the Spring Assembly by extracting toward the Brake Spring end.

Assembly (Figure 13)

Replace the Clutch (850889), Brake (850889) and Anti-Back (850962) Springs as required. Assemble the Springs concentric and square to the Output Shaft.(850891) Assemble the Control Collar over the Output Shaft and Spring Assembly by inserting it from the Brake Spring End (it will be necessary to extend the Brake Springs using long nose pliers.) Place the Brake Spring Tang in any one (1) of the nine (9) Control Collar slots at random.

Assemble the Output Shaft, Springs and Control Collar assembly to the Mounting Plate Assembly by rotating the Output Shaft in the drive direction. Assemble the Retaining Ring (850886) to the Output Shaft at the Mounting Plate end (the smooth surface facing the Brake Hub.) Check the end play between the Hub and the Retaining Ring with a feeler gauge. There should be 0.004” to 0.010” end play. Use a Shim Washer to adjust if necessary.

Rotate the Output Shaft in the drive direction until it reaches a full brake position. With the Clutch Spring Tang **NOT** in slot, insert the Input Hub (851321) by rotating opposite to the drive direction. Select one (1) of ten (10) Control Collar slots for the Clutch Spring Tang that will provide a 0.38” to 0.50” circumferential overtravel of the Control Collar when released.

Note: At this point it may be necessary to reselect one (1) of the nine (9) Control Collar slots for the Brake Spring Tang (release Actuator Lever, remove the Clutch Spring tang from the slot, then move Control Collar axially toward the Input Hub end and rotate it opposite to the drive direction to pick up the next slot). Continue to select Control Collar slots until the 0.38" to 0.50" specification is achieved.

Assemble the Retaining Ring to the Output Shaft at the Input Hub end (the smooth surface facing the Input Hub). Check the end play between the Input Hub and the Retaining Ring with feeler gauge. There should be 0.002" to 0.003" end play on the Input Hub.

Reassemble the unit to the machine.

Note: After the Clutch is assembled to the machine, the Clutch Plate should be free to float on bearing - the Anchor Strap is only there to prevent rotation of the plate.

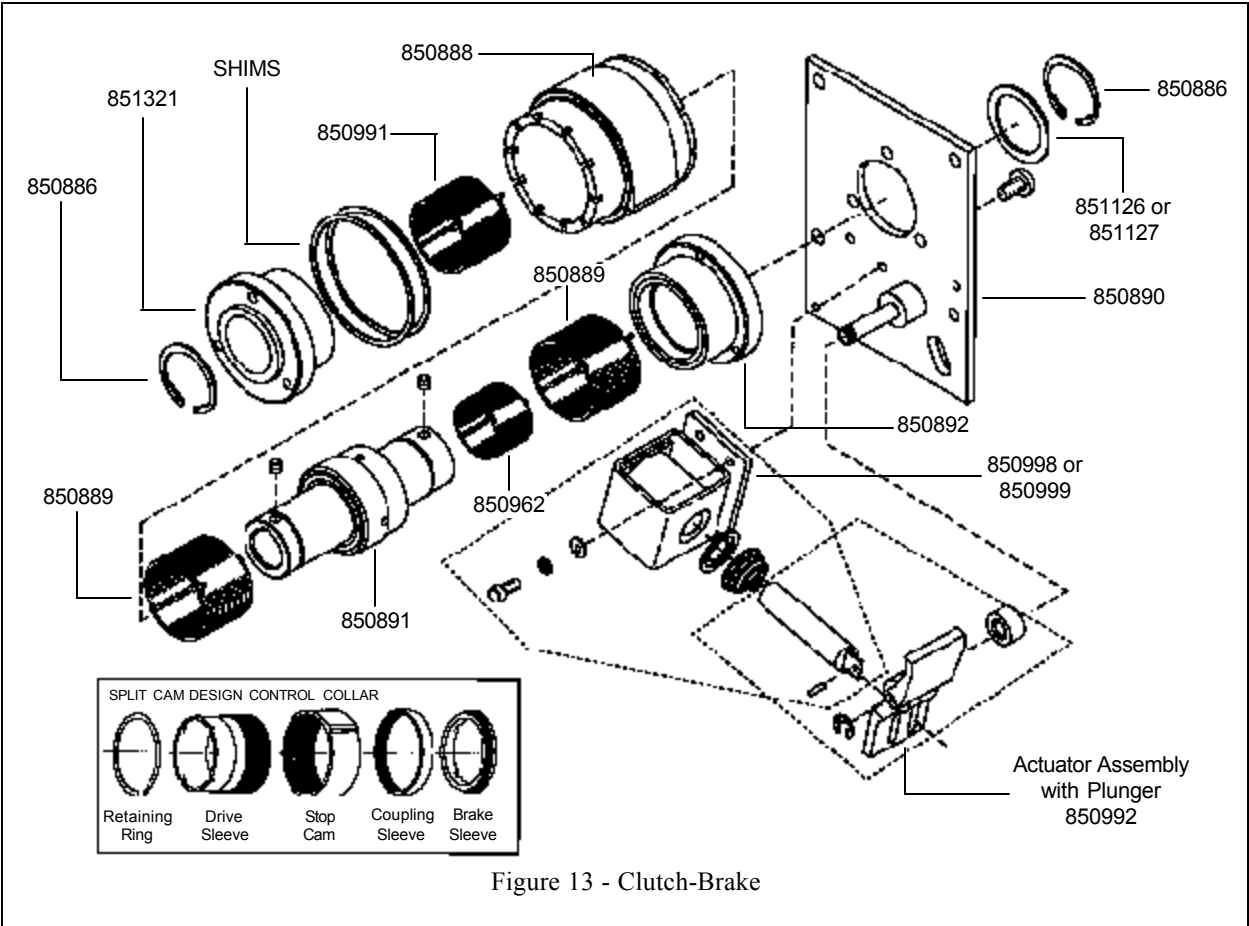

Figure 13 - Clutch-Brake

Lubrication

The clutch-brake unit is designed with the bearing parts made from sintered metal that has been impregnated with oil and normally do not need to be re-lubricated. In cases where there is severe duty, the unit may be re-oiled or flushed out with minimal or no disassembly by using a light bearing oil as used in manufacture (Shell Bearing Infusion Oil #33). If disassembly of the unit for cleaning and oiling is necessary, follow the detailed disassembly instructions to the point needed, flush and wipe parts in the oil to be used for re-lubrication. **Do not use solvents** to clean the parts. To get more cleaning action for the oil, it may be heated while cleaning the components, but bring the parts back to ambient temperature submerged in cool oil.

Coil Replacement

Place the spring onto the plunger with the narrow end towards the actuator. Slide the solenoid onto the actuator and plate assembly. Assemble the solenoid to the plate assembly with the cap screws and washers. **Do not tighten** more than finger tight.

Energize the coil and adjust the gap between the actuator and the top of the collar stop to 0.015" to 0.030" by sliding the solenoid assembly. Note: push the collar toward the actuator to allow for collar movement. Tighten the cap screws.

Control Collar Adjustment (Figure 14)

The stopping position of the head can be changed if necessary by adjusting the position of the stop cam on the control collar sleeve. Turn the machine manually until the driver is in the desired stopping position, then proceed as follows:

Work the Retaining Ring out of its groove and slide it forward on the Drive Sleeve. Slide the cam of the Control Collar Assembly (850888) off of the splines, rotate to align the collar stop with the actuator and slide the cam back on the splines. The actuator pawl will have to be held clear during this operation. Slide the retaining ring back into its groove.

Make sure brake is locked up before proceeding, to insure the proper stop point.

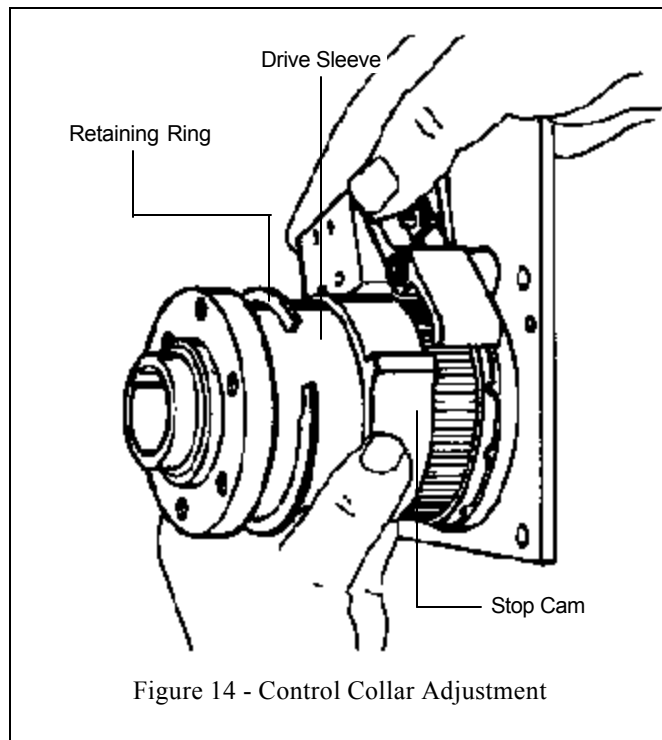
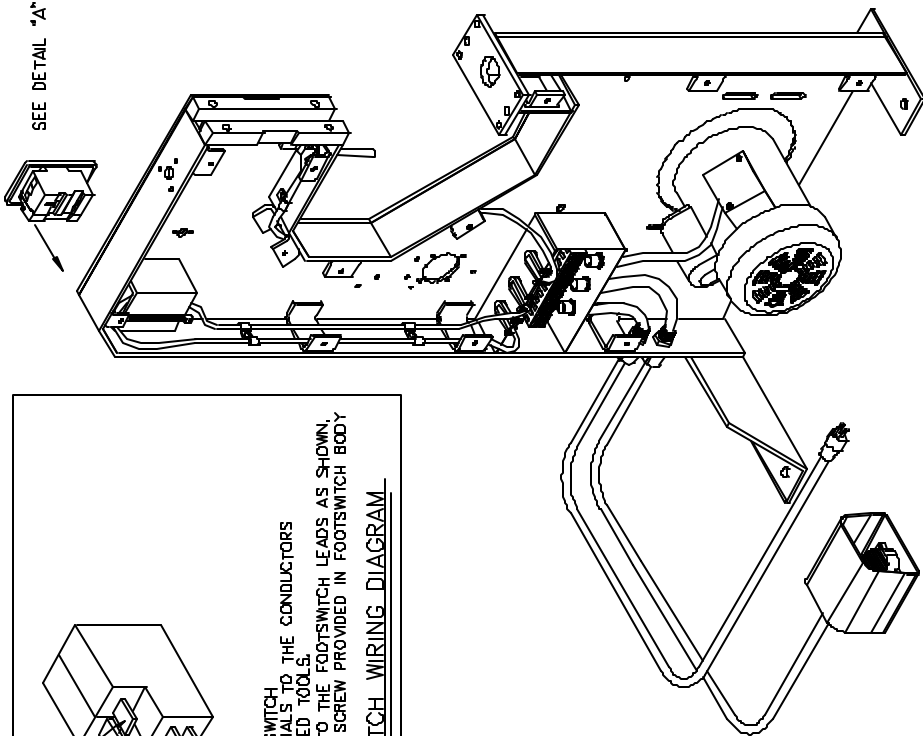
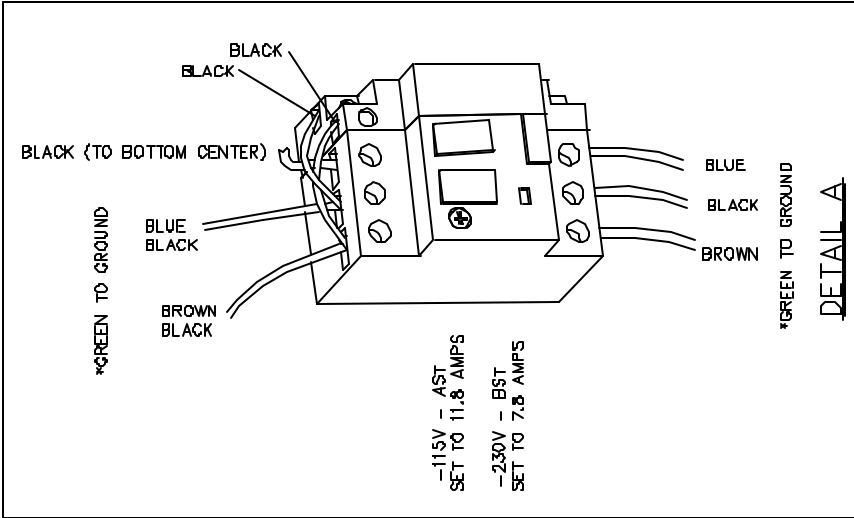

Figure 14 - Control Collar Adjustment

Wiring Diagram



NOTE:

1. STANDARD D.P.D.T. SWITCH
2. ATTACH WIRE TERMINALS TO THE CONDUCTORS USING ONLY APPROVED TOOLS.
3. FASTEN TERMINALS TO THE FOOTSWITCH LEADS AS SHOWN.
4. FASTEN GROUND TO SCREW PROVIDED IN FOOTSWITCH BODY

FOOT SWITCH WIRING DIAGRAM

Complete Wiring with Detail

Wiring Diagram

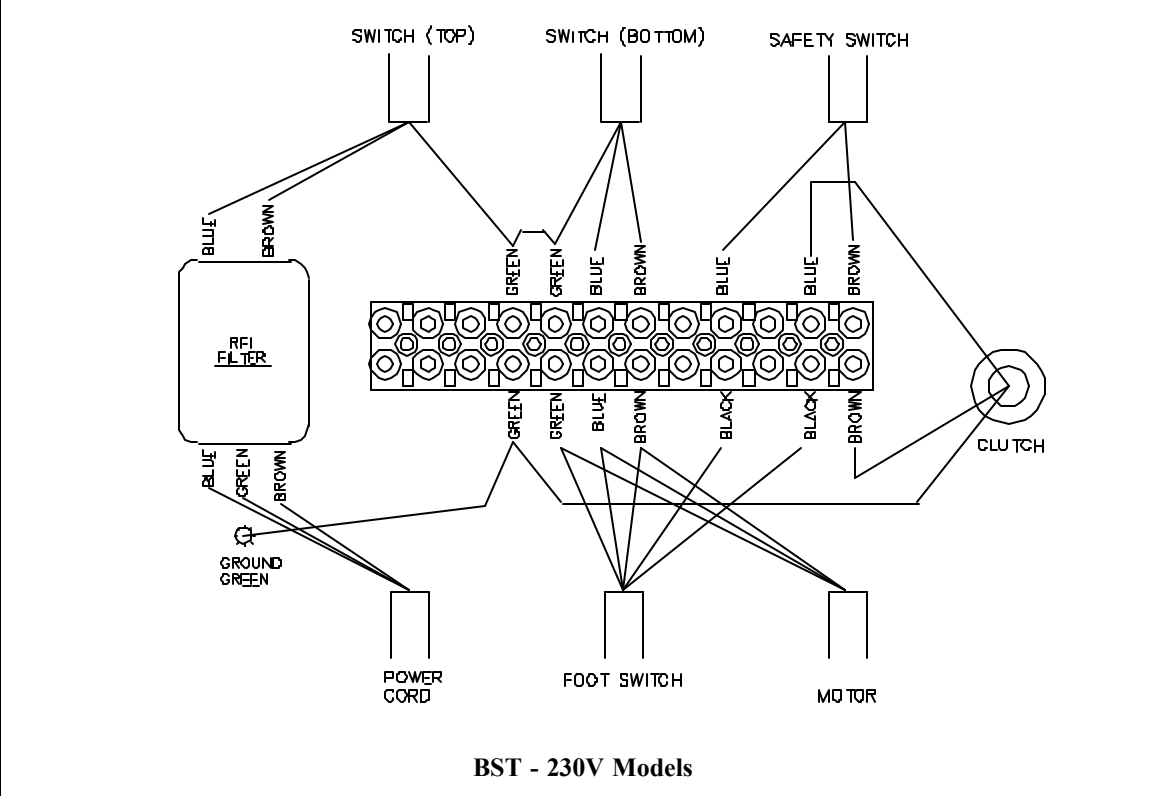
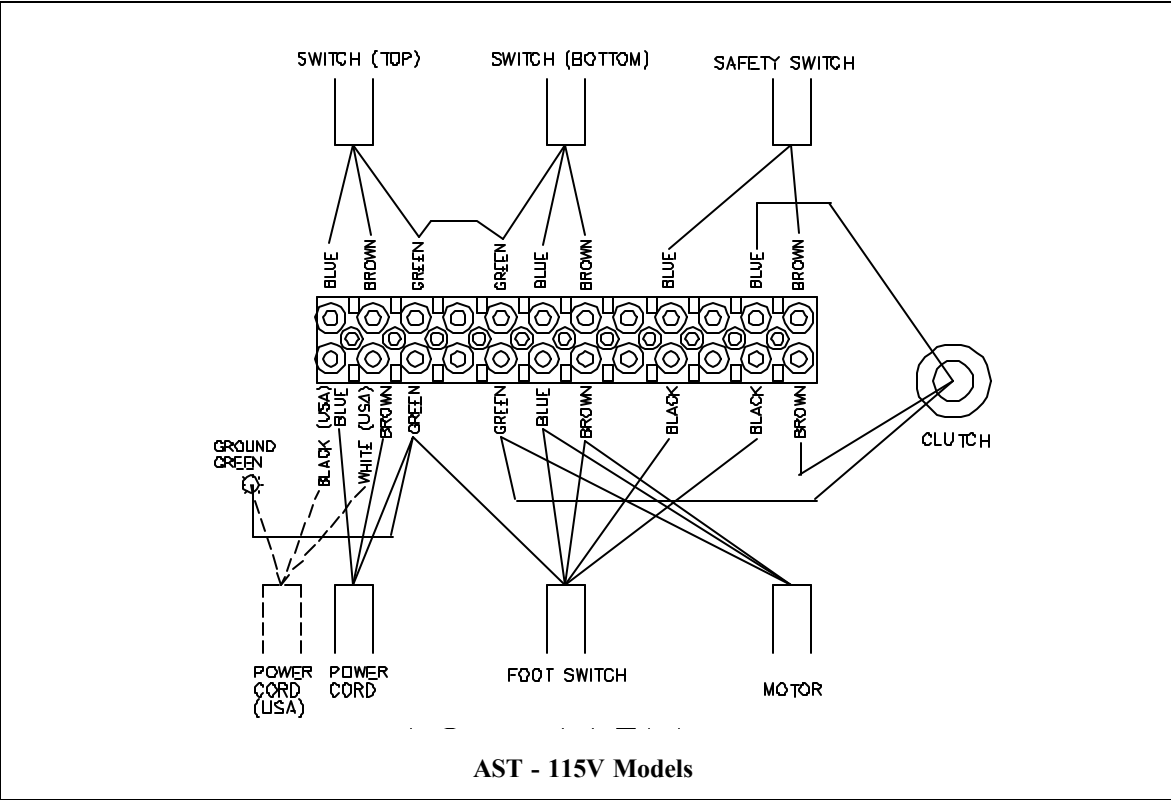

Motor Assemblies

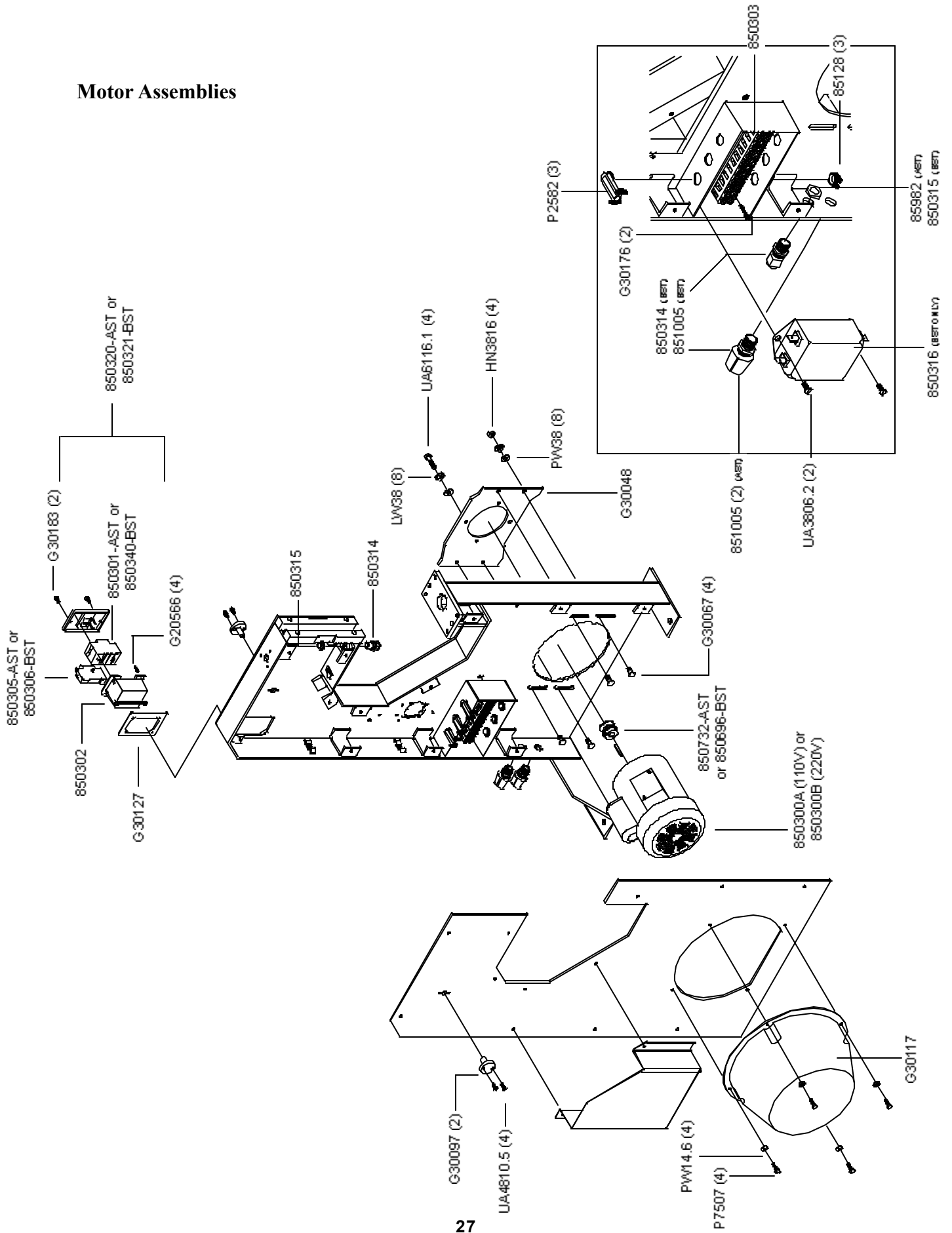

Motor Assemblies

PART No.	DESCRIPTION	QUANTITY
G20566	Screw M4 x 0.7 x 20	4
G30048	Motor Mounting Plate	1
G30067	Bolt 3/8 - 16 x 1	4
G30097	Adjuster Pivot Pin	2
G30117	Motor Cover	1
G30127	Starter Mounting Flange	1
G30176	Screw M4 x 0.7 x 25	2
G30183	Screw, Tap 6x3/8	2
HN3816	Hex Nut 3/8 - 16	4
LW38	Lock Washer 3/8	8
P2582	Connector 3/8 x 90 Degrees	3
P7507	Screw 1/4 - 20 x 3/4	4
PW14.6	Washer	4
PW38	Washer 3/8	8
UA3806.2	Screw 10 - 32 x 3/8	2
UA4810.5	Screw 1/4 - 20 x 5/8	2
UA6116.1	Screw 3/8-16x1	4
850300A	Motor 1/2 HP - 115V	1
850300B	Motor 1/2 HP - 230V	1
850301	Motor Starter GV2M14	1
850302	Starter Enclosure	1
850303B	Terminal Strip - Holes	1
850305	UV Trip - 115V	1
850306	UV Trip - 230V	1
850314	Strain Relief - AST Models	1
850315	Strain Relief Nut	1
850316	RFI Filter	1
850320	Starter Assembly - 1/2,115V	1
850321	Starter Assembly - 1/2,230V	1
850340	Motor Starter GV2M10	1
850696	Pulley - AK20 - 5/8	1
850732	Pulley AK17 x 5/8	1
851005	Strain Relief - BST Models	2
85128	Connector 3/8	3
85982	Lock Nut 1/2	1

Guard Assembly

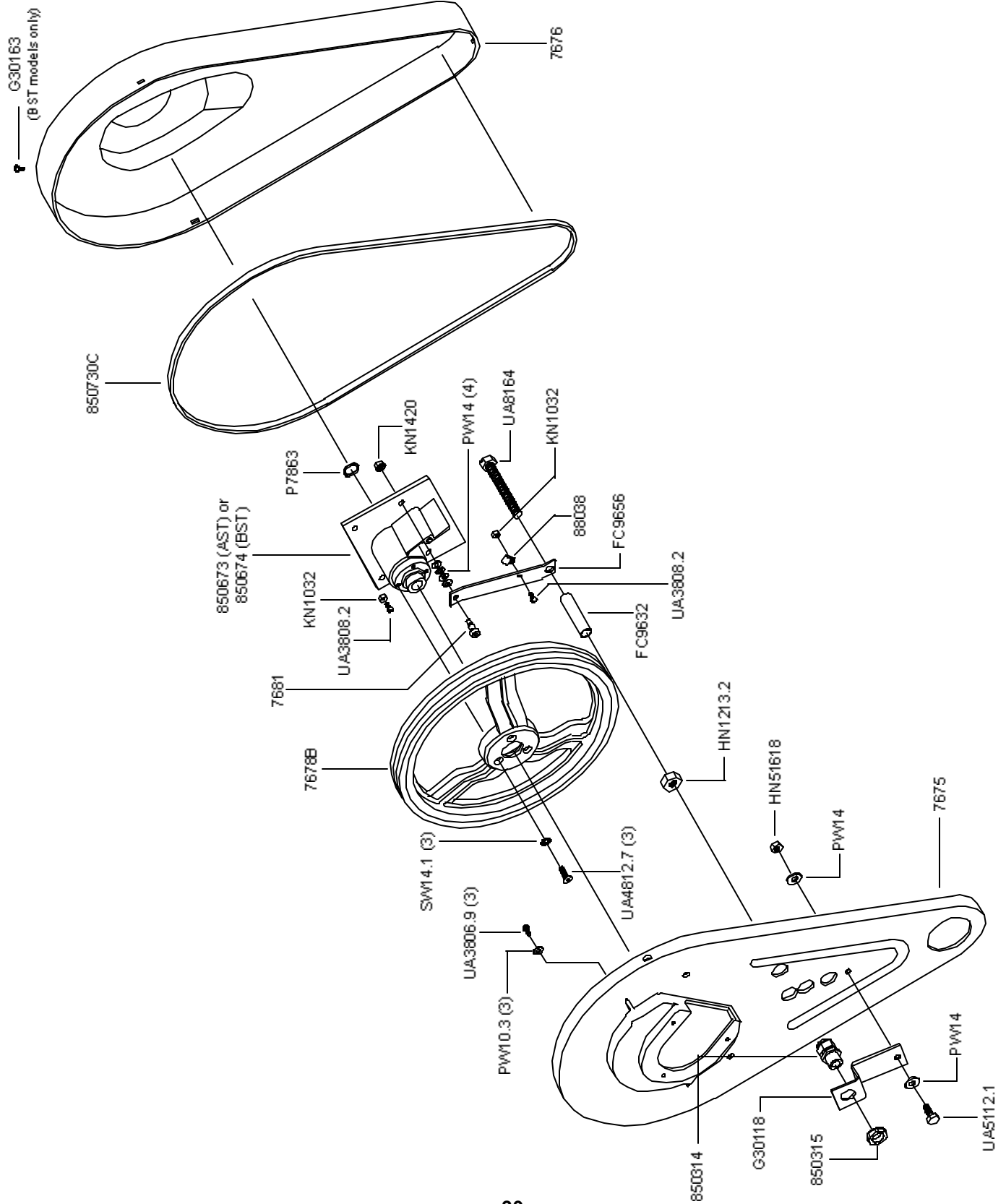

Guard Assembly

PART No.	DESCRIPTION	QUANTITY
FC9632	Anchor Spacer	1
FC9656A	Clutch Anchor Assembly	1
G30118	Belt Guard Bracket	1
G30163	Self Tap Screw 10 x 3/8	1
HN1213.2	Nut 1/2 - 13	1
HN51618	Hex Nut	1
KN1032	Kep Nut 10 - 32	2
KN1420	Nut 1/4	1
P7863	Retaining Ring	1
PW10.3	Washer 3/16	3
PW14	Washer 1/4	6
SW14.1	Lock Washer	3
UA3806.9	Screw 10 - 32 x 3/8	3
UA3808.2	Screw 10 - 32 x 1/2	2
UA4812.7	Screw 1/4 - 20 x 3/4	3
UA5112.1	Screw 5/16 - 18 x 3/4	1
UA8164	Screw 1/2 - 13 x 4	1
7675	Belt Guard	1
7676	Belt Guard	1
7678B	Drive Pulley - 4L	1
7681	Screw Clutch Anchor	1
850314	Strain Relief	1
850315	Strain Relief Nut	1
850673	Electric Clutch - 115V	1
850674	Electric Clutch - 230V	1
850730C	V-Belt 1/2 x 60	1
88038	Nylon Cable Clamp	1

Internal Assemblies

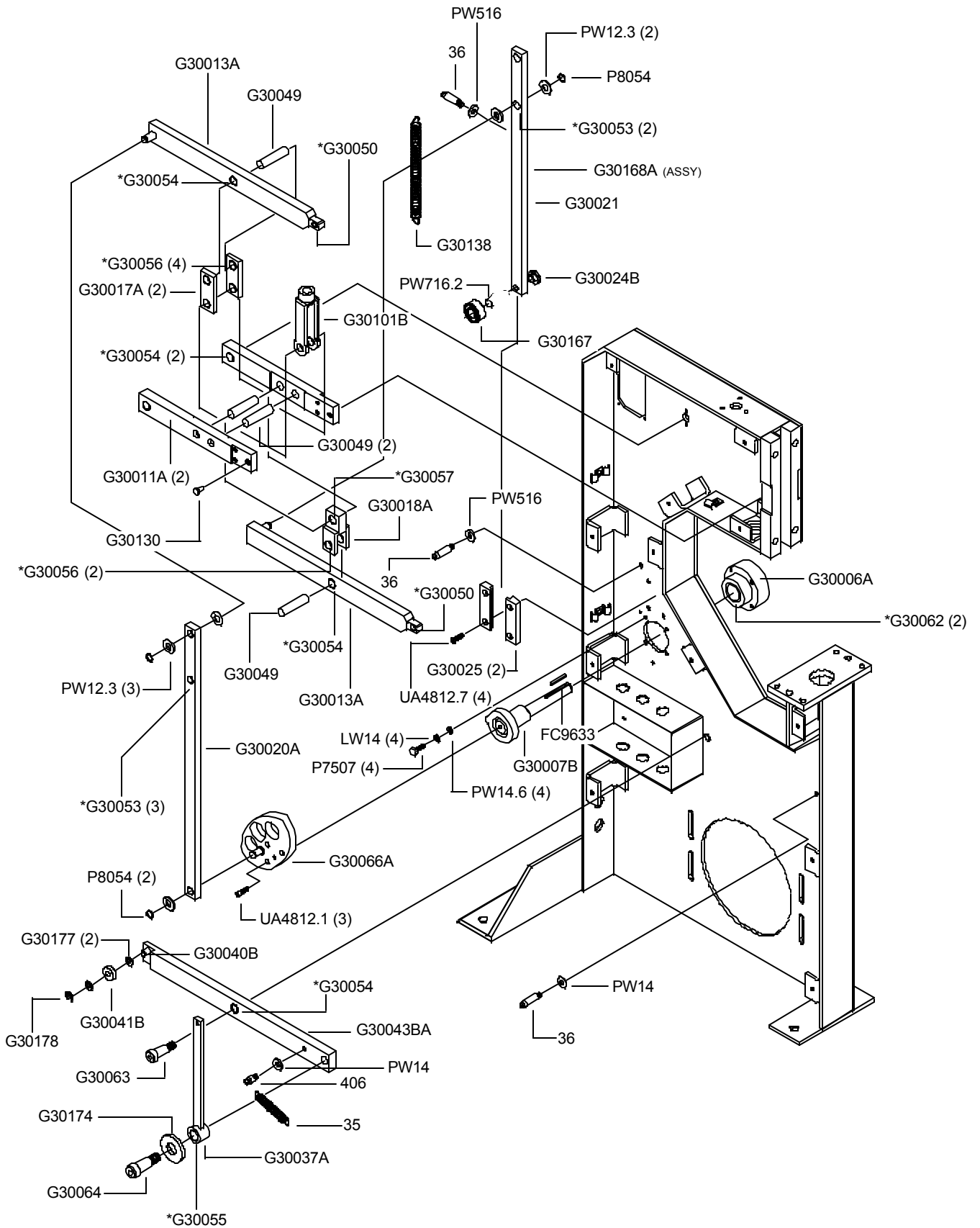

Internal Assemblies

PART No.	DESCRIPTION	QUANTITY
FC9633	Key	1
G30006A	Bearing Housing Assembly	1
G30007B	Crank Shaft Assembly	1
G30011A	Adjuster Lever Assembly	2
G30013A	Drive Lever Assembly	2
G30017A	Pivot Link Assembly	2
G30018A	Pivot Fork Assembly	1
G30020A	Upright Link Assembly	1
G30021	Cam Upright Link	1
G30024B	Hex Nut Guide Stud	1
G30025	Cam Guide	2
G30037A	Clincher Upright Link Assembly	1
G30040B	Cam Follower Stud	1
G30041B	Clincher Cam Follower	1
G30043BA	Clincher Lever Assembly	1
G30049	Dowel Pin 5/8 x 2-1/2	4
G30063	Screw 5/8 x 1	1
G30064	Screw 3/4 x 1-1/4	1
G30066A	Bender Cam Assembly	1
G30168A	Cam Upright Link Assembly	1
G30101B	Adjuster Yoke	1
G30130	Adjuster Stud	1
G30151	Extension Spring	1
G30167A	Cam Follower Assembly	1
G30168A	Cam Upright Link Assembly	1
G30174	Spacer - M Series	1
G30177	Flat Washer	2
G30178	Retaining Ring	1
LW14	Lock Washer 1/4	4
P7507	Screw 1/4 - 20 x 3/4	4
P8054	Retaining Ring	3
PW12.3	Washer Zinc 1/2	7
PW14	Washer 1/4	2
PW14.6	Washer	4
PW516	Washer 5/16	2
PW716.2	Washer 7/16 SAE	2
UA4812.1	Screw 1/4-20 x 3/4	3
UA4812.7	Screw 1/4-20 x 3/4	4
35	Clincher Slide Link Spring	1
36	Pin	3
406	Clincher Oper. Lever Spring Screw	1

* Contain self-lubricating bearings which can be purchased separately.

External Assemblies

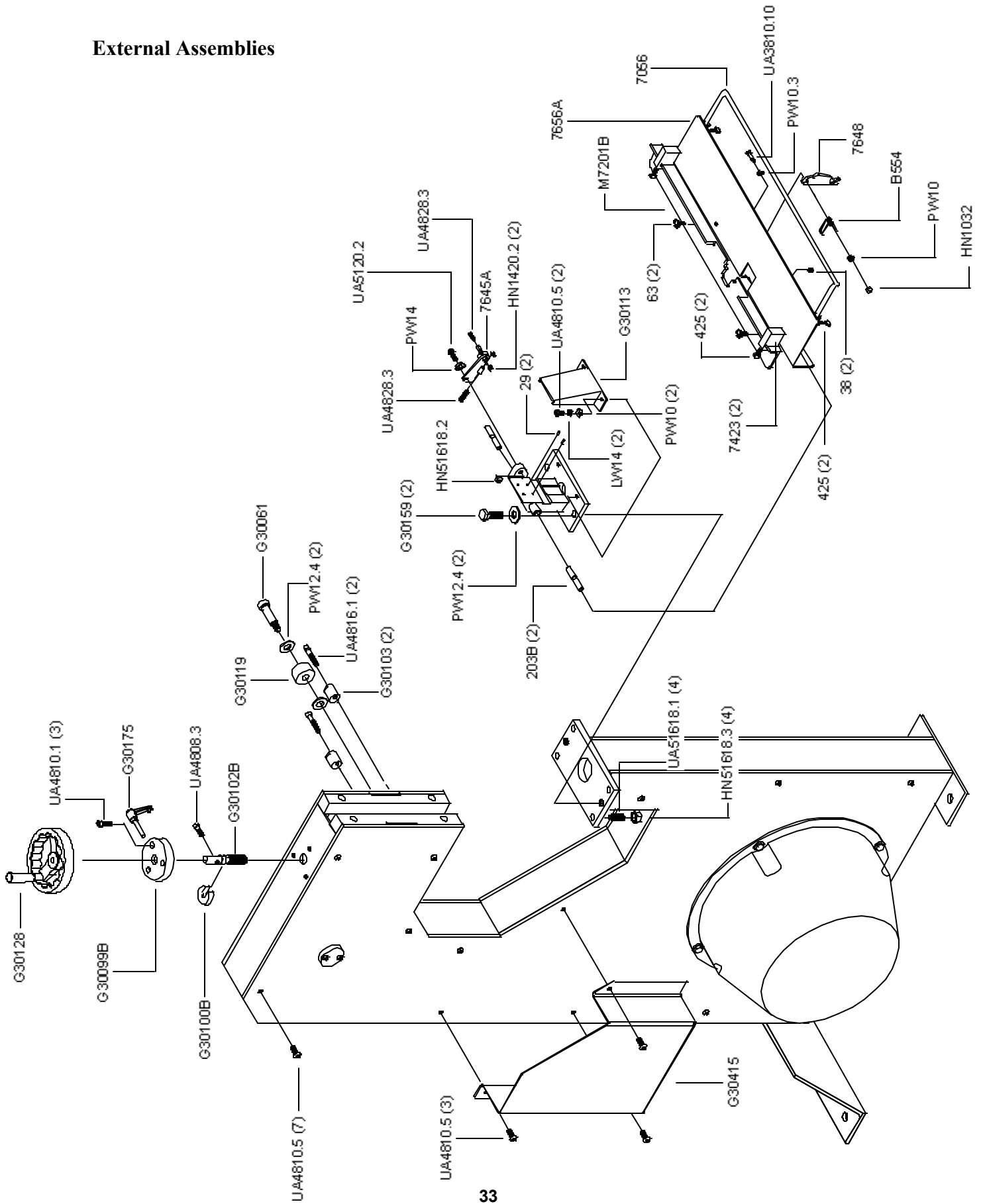

External Assemblies

PART No.	DESCRIPTION	QUANTITY
B554	Torsion Spring	1
G30061	Shoulder Screw 1/2x1-1/2	1
G30099B	Adjustment Crank Housing	1
G30100B	Adjuster Crank Shaft Insert	1
G30102B	Adjuster Shaft	1
G30103	Adjuster Stop	2
G30113	Clincher Guard	1
G30119	Paper Thickness Gage	1
G30128	Hand Wheel	1
G30159	Screw 1/2-20x1-1/4	2
G30175	Adjuster Crank	1
G30415	Tool Kit Hanger	1
HN1032	Nut 10-32	1
HN1420.2	Hex Jam Nut 1/4-20	2
HN51618.2	Hex Jam Nut 5/16-18	1
HN51618.3	Hex Jam Nut 5/16-18	4
LW14	Lock Washer	2
M7201B	Work Guide	1
PW10	Washer	3
PW10.3	Flat Washer 3/16	1
PW12.4	Washer Black 1/2	4
PW14	Lock Washer 1/4	1
UA3810.10	Shoulder Screw 1/4x5/8	1
UA4808.3	Screw 1/4-20x1/2	1
UA4810.1	Screw 1/4-20x5/8	3
UA4810.5	Screw 1/4-20x5/8	12
UA4816.1	Screw 1/4-20x1	2
UA4828.3	Set Screw - Cup Point	2
UA5120.2	Screw 5/16-18x1-1/4	1
UA51618.1	Screw 5/16-18x7/8	4
203B	Work Table Swivel Pin	2
29	Dowel	2
38	Clincher Slide Adjustment Screw	2
425	Wire Guide Spring Holder Screw	4
63	Work Guide Screw	2
7056	Work Table Extension	1
7423	Work Stop	2
7645A	Table Support Bracket Asy - RH	1
7648	Table Support	1
7656A	Work Table Assembly	1

Wire and Guard Assemblies

Need Updated Drawing

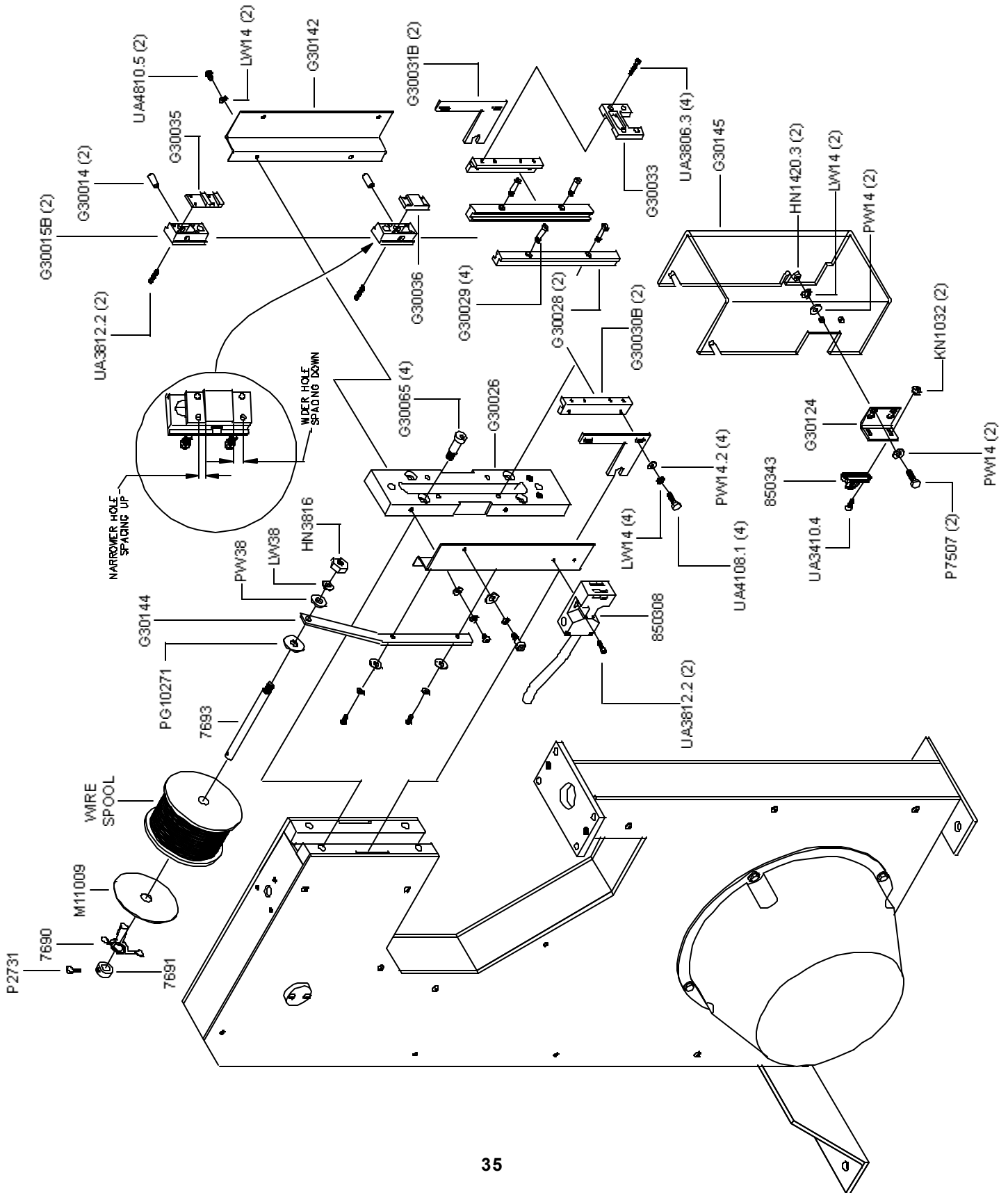

Wire and Guard Assemblies

PART No.	DESCRIPTION	QUANTITY
G30014	Slider Pin	2
G30015B	Slider	2
G30026	Face Plate Adapter	1
G30028	Slider Guide	2
G30029	Slider Guide Screws	4
G30030B	Adjuster Slide	2
G30031B	Adjuster Fork	2
G30033	Adjuster Plate	1
G30035	Drive Plate Adapter	1
G30036	Bender Plate Adapter	1
G30065	Screw 1/2x1	4
G30124	Actuator Key Bracket	1
G30142	Guard - Right	1
G30144	Spool Bracket	1
G30145	Head Guard	1
HN1420.13	Nut 1/4 - 20 Nylon	2
HN3816	Hex Nut 3/8 - 16	1
KN1032	Kep Nut 10 - 32	2
LW14	Lock Washer	8
LW38	Lock Washer 3/8	1
M11009	Plastic Washer	1
P2731	Thumb Screw 1/4 - 20 x 3/4	1
P7507	Screw 1/4 - 20 x 3/4	2
PG10271	Washer 9/16	1
PW14	Washer 1/4	4
PW14.2	Washer Zinc	2
PW38	Washer 3/8	1
UA3410.4	Screw 10-32x5/8	1
UA3806.3	Screw 10-32x3/8	2
UA3812.2	Screw 10-32x3/4	4
UA4108.1	Screw 1/4-20x1/2	4
UA4810.5	Screw 1/4-20x5/8	2
7690	Tension Spring	1
7691	Set Collar - Reamed	1
7693	Spool Stud	1
850308	Safety Interlink Switch	1
850343	Interlock Switch Key	1

The M19 Stitcher Machine

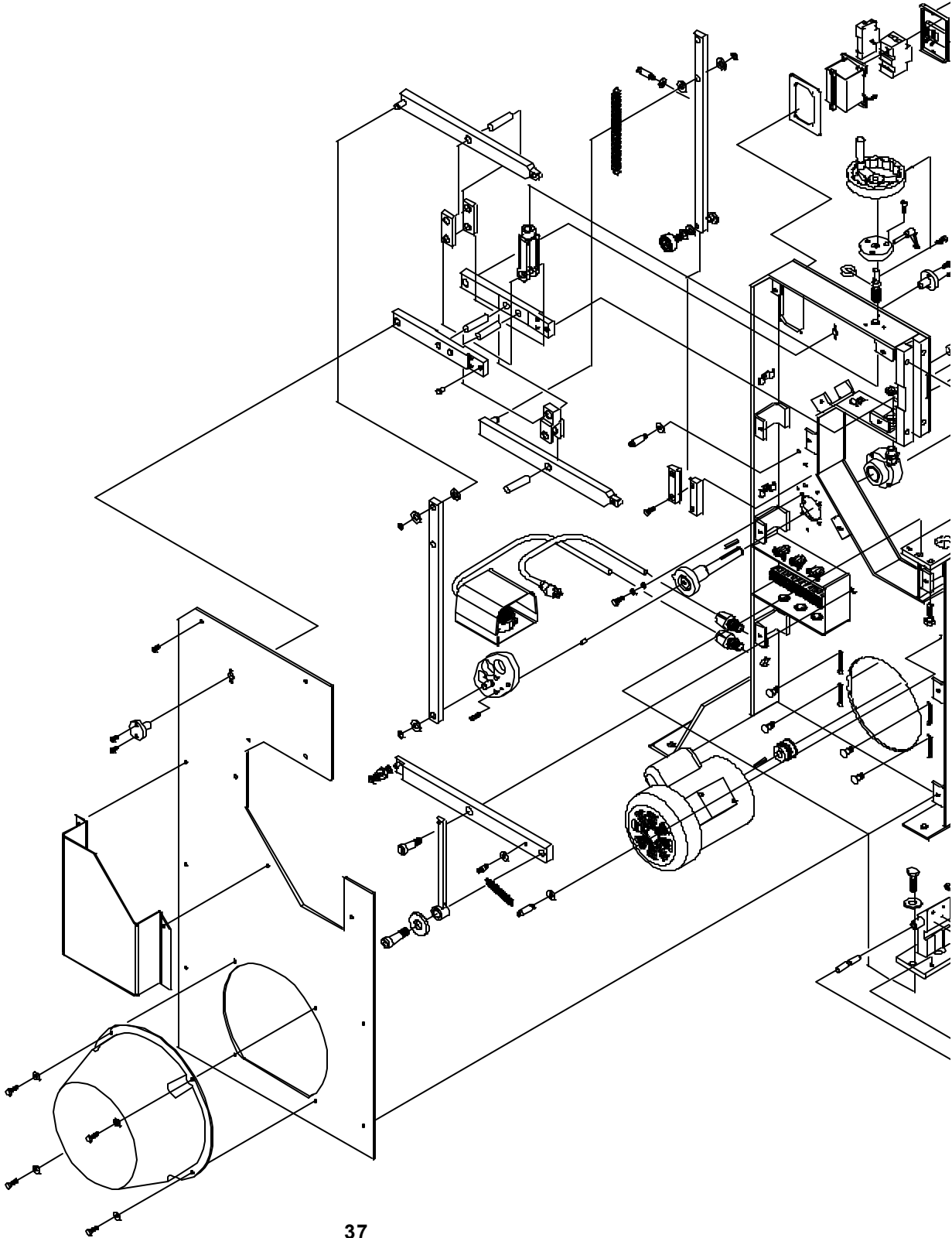

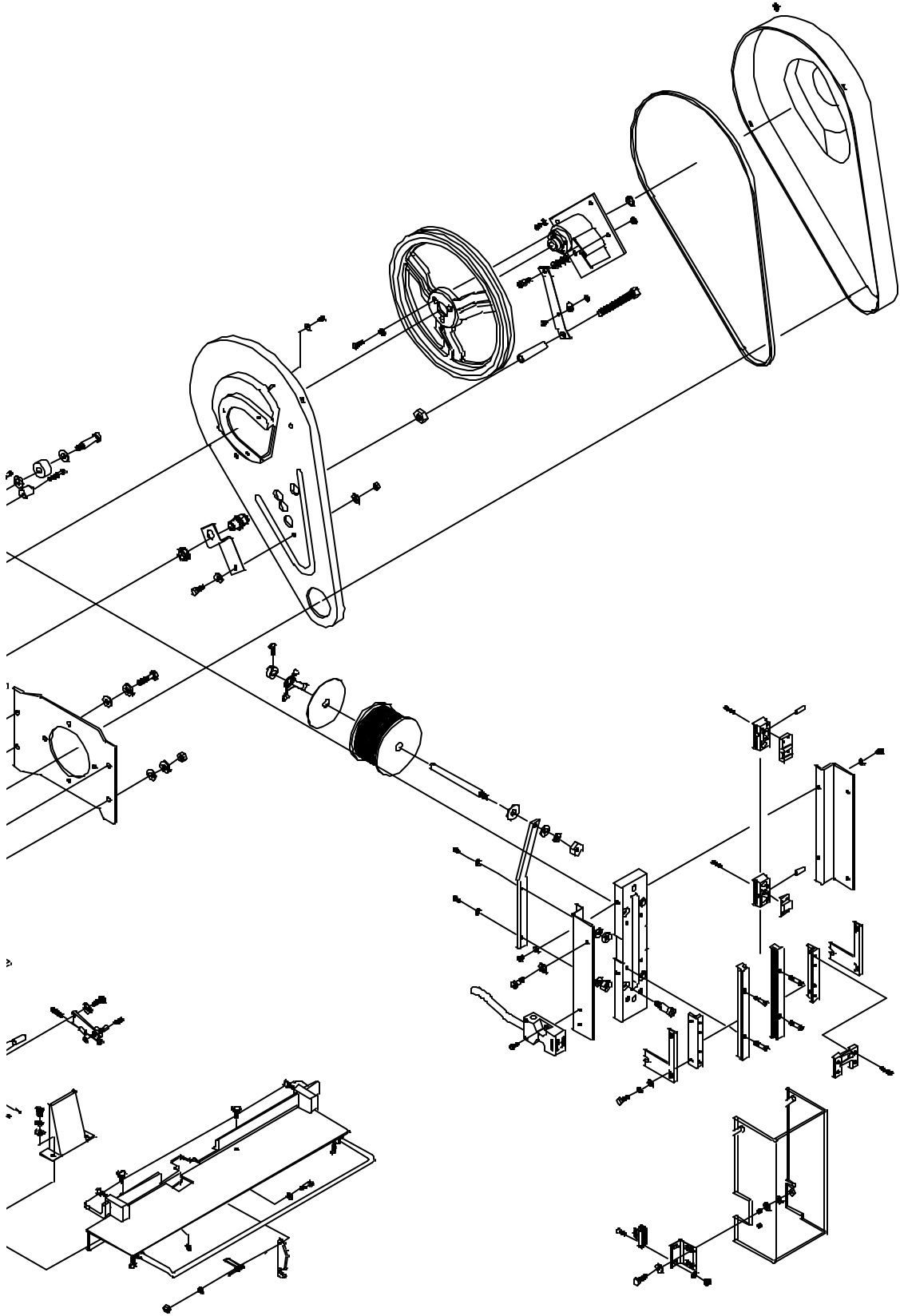

Part Number / Description Cross-Reference

PART NO.	DESCRIPTION	QUANTITY	PART NO.	DESCRIPTION	QUANTITY
18001BHD20241/2	Stitcher Head Assembly - M19	1	85128	Connector 3/8	3
2024G5	Wire Spool - Galvanized	1	85982	Lock Nut 1/2	1
203B	Work Table Swivel Pin	2	86243	Power Cord - 115V	1
29	Dowel	2	88038	Nylon Cable Clamp	1
35	Clincher Slide Link Spring	1	B554	Torsion Spring	1
36	Pin	3	FC9632	Anchor Spacer	1
38	Clincher Slide Adjustment Screw	2	FC9633	Key	1
406	Clincher Oper Lever Spring Screw	1	FC9656A	Clutch Anchor Assembly	1
425	Wire Guide Spring Holder Screw	4	G20566	Screw M4x0.7x20	4
63	Work Guide Screw	2	G30006A	Bearing Housing Assembly	1
7056	Work Table Extension	1	G30007B	Crank Shaft Assembly	1
7423	Work Stop	2	G30011A	Adjuster Lever Assembly	2
7645A	Table Support Bracket Asy - RH	1	G30013A	Drive Lever Assembly	2
7648	Table Support	1	G30014	Slider Pin	2
7656A	Work Table Assembly	1	G30015B	Slider	2
7659	Table Extender Bracket	2	G30017A	Pivot Link Assembly	2
7675	Belt Guard	1	G30018A	Pivot Fork Assembly	1
7676	Belt Guard	1	G30020A	Upright Link Assembly	1
7678B	Drive Pulley - 4L	1	G30021A	Cam Upright Link Assembly	1
7681	Screw Clutch Anchor	1	G30023A	Cam Follower Assembly	1
7690	Tension Spring	1	G30024B	Hex Nut Guide Stud	1
7691	Set Collar - Reamed	1	G30025	Cam Guide	2
7693	Spool Stud	1	G30026	Face Plate Adapter	1
850300A	Motor 1/2 HP - 115V	1	G30028	Slider Guide	2
850300B	Motor 1/2 HP - 230V	1	G30029	Slider Guide Screws	4
850301	Motor Starter	1	G30030B	Adjuster Slide	2
850302	Starter Enclosure	1	G30031B	Adjuster Fork	2
850303B	Terminal Strip - Holes	1	G30033	Adjuster Plate	1
850305	UV Trip - 115V	1	G30035	Drive Plate Adapter	1
850306	UV Trip - 230V	1	G30036	Bender Plate Adapter	1
850308	Safety Interlock Switch	1	G30037A	Clincher Upright Link Assembly	1
850313	Footswitch Guard	1	G30040B	Cam Follower Stud	1
850314	Strain Relief	2	G30041B	Clincher Cam Follower	1
850315	Strain Relief Nut	1	G30043BA	Clincher Lever Assembly	1
850316	RFI Filter	1	G30044A	Clincher Mounting Assembly	1
850317	Clutch, Wire Harness	1	G30048	Motor Mounting Plate	1
850318	Footswitch, Wired	1	G30049	Dowel Pin 5/8x2-1/2	4
850319	Safety Switch, Wired - Bottom Mount	1	G30061	Shoulder Screw 1/2x1-1/2	1
850320	Starter Assembly 1/2 - 115V	1	G30063	Shoulder Screw 5/8x1	1
850321	Starter Assembly 1/2 - 230V	1	G30064	Shoulder Screw 3/4x1-1/4	1
850337	Wire Terminal Ring	1	G30065	Screw 1/2x1	4
850340	Motor Starter	1	G30066A	Bender Cam Assembly	1
850343	Interlock Switch Key	1	G30067	Bolt 3/8-16x1	4
850673	Electric Clutch - 115V	1	G30097	Adjuster Pivot Pin	2
850674	Electric Clutch - 230V	1	G30099B	Adjustment Crank Housing	1
850696	Pulley	1	G30100B	Adjuster Crank Shaft Insert	1
850730C	V-Belt	1	G30101B	Adjuster Yoke	1
850731	Pulley	1	G30102B	Adjuster Shaft	1
850732	Pulley	1	G30103	Adjuster Stop	2
851005	Strain Relief	2	G30113	Clincher Guard	1

Part Number / Description Cross-Reference

PART NO.	DESCRIPTION	QUANTITY	PART NO.	DESCRIPTION	QUANTITY
G30117	Motor Cover	1	PW14	Flat Washer	6
G30118	Belt Guard Bracket	1	PW14.2	Washer Zinc	2
G30119	Paper Thickness Gage	1	PW14.6	Washer	4
G30124	Actuator Key Bracket	1	PW38	Washer	8
G30127	Starter Mounting Flange	1	PW516	Washer	2
G30128	Hand Wheel	1	PW716.2	Washer	2
G30130	Adjuster Stud	1	SW14.1	Lock Washer	3
G30138	Extension Spring	1	UA3410.4	Screw 10-32x5/8	1
G30142	Guard - Right	1	UA3806.2	Screw 10-32x3/8	2
G30143	Guard - Left	1	UA3806.3	Screw 10-32x3/8	4
G30144	Spool Bracket	1	UA3806.9	Screw 10-32x3/8	3
G30145	Head Guard	1	UA3808.2	Screw 10-32x1/2	2
G30151	Extension Spring	1	UA3810.10	Shoulder Screw 1/4x5/8	1
G30159	Screw 1/2-20x1-1/4	2	UA3812.2	Screw 10-32x3/4	4
G30163	Self Tapping Screw	1	UA4108.1	Screw 1/4-20x1/2	4
G30174	Spacer - M Series	1	UA4808.3	Screw 1/4-20x1/2	1
G30175	Adjuster Crank	1	UA4810.1	Screw 1/4-20x5/8	3
G30176	Screw M4x.7x25	2	UA4810.5	Screw 1/4-20x5/8	2
G30177	Flat Washer	2	UA4812.1	Screw 1/4-20x3/4	3
G30178	Retaining Ring	1	UA4812.7	Screw 1/4-20x3/4	3
G30183	Self Tapping Screw	2	UA4816.1	Screw 1/4-20x1	2
G30415	Tool Kit Hanger	1	UA4828.3	Set Screw - Cup Point	2
HN1032	Nut 10-32	1	UA5112.1	Screw 5/16-18x3/4	1
HN1213.2	Hex Jam Nut 1/2-13	1	UA5120.2	Screw 5/16-18x1-1/4	1
HN1420.13	Nut 1/4-20 Nylon	2	UA51618.1	Screw 5/16-18x7/8	4
HN1420.2	Hex Jam Nut 1/4-20	2	UA6116.1	Screw 3/8-16x1	4
HN3816	Hex Nut 3/8-16	1	UA8164	Screw 1/2-13x4	1
HN51618	Hex Nut 5/16-18	1			
HN51618.2	Hex Jam Nut 5/16-18	1			
HN51618.3	Hex Jam Nut 5/16-18	4			
K1033	Work Table Asy Complete - Single	1			
KN1032	Kep Nut 10-32	2			
KN1420	Kep Nut 1/4	1			
LW10	Lock Washer	4			
LW14	Lock Washer	4			
LW38	Lock Washer	1			
M11009	Plastic Washer	1			
M7201B	Work Guide	1			
P2582	Connector 3/8x90 Degrees	3			
P2731	Thumb Screw 1/4-20x3/4	1			
P6371	Retaining Ring	1			
P7507	Screw 1/4-20x3/4	4			
P7863	Retaining Ring	1			
P8054	Retaining Ring	3			
PG10271	Washer 9/16	1			
PW10	Washer	3			
PW10.3	Flat Washer 3/16	3			
PW10.6	Washer	4			
PW12.3	Washer Zinc 1/2	5			
PW12.4	Washer Black 1/2	4			

REGISTRATION

To better service your wire stitching needs, please take a moment to fill out and return this registration card.

CUSTOMER

Name : _____
(First) (Middle Initial) (Last)
Company : _____
Street Address : _____
City : _____ State/Province : _____ Zip : _____
Country : _____
Phone : _____ Fax : _____ E-mail : _____

PRODUCT

Machine(s) Purchased : _____
Serial Number(s) : _____
With Head(s) : _____
(Type/Quantity Purchased)
Serial Number(s) : _____
Head(s) Purchased : _____
Serial Number(s) : _____

DEALER

Date Received : _____
Dealer Name : _____
Dealer Street Address : _____
City : _____ State/Province : _____ Zip : _____
Country : _____
Dealer Phone : _____

Other Bindery Products Used : _____

Would you like information sent to you about new products that would benefit your company? Yes No

Please take a moment to fill out the attached card and mail it to DeLuxe Stitcher Company, Inc. In addition duplicate the information for your records to assist when making further inquiries.

PRODUCT

Machine(s) Purchased : _____
Serial Number(s) : _____
With Head(s) : _____
(Type/Quantity Purchased)
Serial Number(s) : _____
Head(s) Purchased : _____
Serial Number(s) : _____

DE LUXE STITCHER GRAPHIC ARTS REPRESENTATIVE

Date Received : _____
Dealer Name : _____
Dealer Street Address : _____
City : _____ State/Province : _____ Zip : _____
Country : _____
Dealer Phone : _____

**PLAC:
STAM
HERE**

**DELUXE STITCHER
COMPANY INC.**
6635 West Irving Park Road
Chicago, Illinois 60634-2410 U.S.A.
Attn: Customer Service

LIMITED WARRANTY

DeLuxe Stitcher Company, Inc. warrants to the original retail purchaser that this product is free from defects in material and workmanship and agrees to repair or replace, at DeLuxe Stitcher's option, any defective product within 90 days from the date of purchase. This warranty is not transferable. It covers damage resulting only from defects in material or workmanship and does not cover conditions or malfunctions resulting from normal wear, neglect, abuse or accident.

This warranty is in lieu of all other express warranties. Any warranty of merchantability or fitness for a particular purpose is limited to the duration of this warranty. DeLuxe Stitcher shall not be liable for any incidental or consequential damages.

Some states do not allow limitations on how long an implied warranty lasts, or the exclusion or limitation of incidental or consequential damages, so the above limitations or exclusions may not apply to you. This warranty gives you specific legal rights and you may also have other rights which vary from state to state.

To obtain warranty service you must return the product, at your expense, together with proof of purchase to an authorized DeLuxe Stitcher Company Graphic Arts Dealer.

Always use genuine DeLuxe Stitcher parts. When ordering parts, please identify the part number, the part name, the wire size and crown size of your Stitcher.

DeLuxe Stitcher Company, Inc.
Chicago, Illinois 60634-2410
Phone: 773-777-6500 800-634-0810
Fax: 773-777-0156 800-417-9251
E-mail: info@deluxestitcher.com
Web Site: <http://www.deluxestitcher.com>



Declaration of Conformity

We, DeLuxe Stitcher Company, Inc.

6635 West Irving Park Road
Chicago, Illinois 60634-2410 U.S.A
Telephone 773-777-6500
Facsimile 773-777-0156

hereby declare under our sole responsibility that the

M19-BST Stitching/Stapling Machines

to which this declaration relates is in conformity with the following European product safety directives:

Machinery Safety Directive

(89/392/EEC and amendments
91/368/EEC, 93/44/EEC, 93/68/EEC)

Electromagnetic Compatibility Directive

(89/336/EEC and amendments
91/C162/08, 92/31/EEC, 93/68/EEC)

as is verified by compliance with the following standards:

EN 60204-1:1992	prEN 894-1:1992	prEN 953:1992
EN 294:1992	prEN 894-3:1992	EN 55014:1193
prEN 614-1:1991	prEN 1050:1993	EN 55104:1995

Executed for DeLuxe Stitcher Company, Inc.

this first day of September in the year 2002

By Frank P. Cangelosi Signature *Frank P. Cangelosi*

Title President



